

AIRTEC

Specialisti della pneumatica

**CATALOGO
GENERALE**

GENERAL CATALOGUE

2024

Più di 40 anni di storia al servizio dei professionisti

More than 40 years of history, supporting the professional customers.

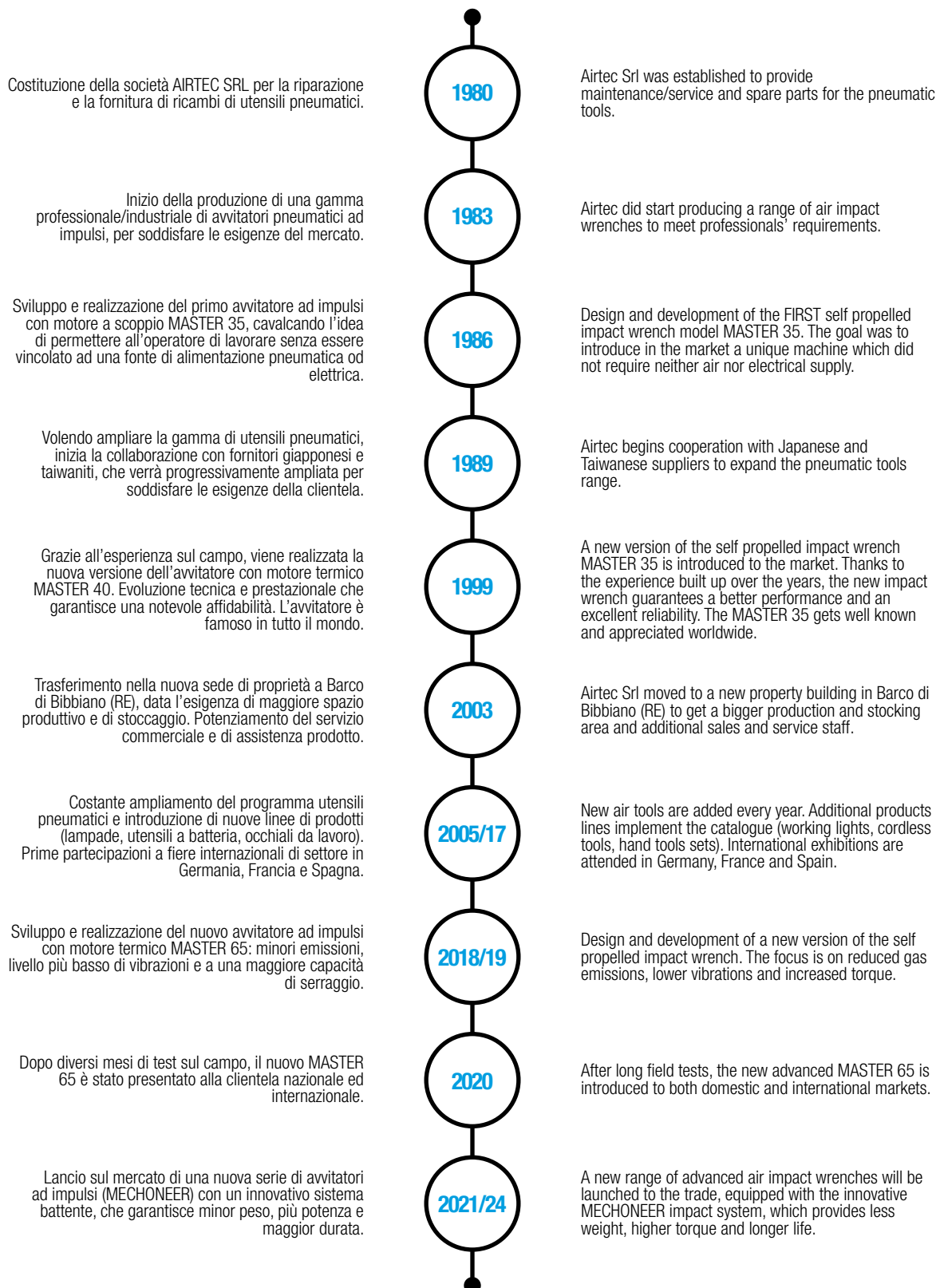

INDICE

index

4 - 7

Master 65

Master 65

8 - 27

Avvitatori ad impulsi

Impact wrenches lines

28 - 33

Bussole

Impact sockets

34 - 39

Avvitatori a cricchetto

Ratchet wrenches

40 - 45

Cacciaviti reversibili

Reversible screwdrivers

46 - 51

Trapani

Drills

52 - 55

Maschiatrici

Air tappers

56 - 67

Smerigliatrici

Grinders

68 - 71

Troncatrici

Cut off tools

72 - 85

Levigatrici e pulitrici

Sanders and polishers

86 - 91

Martelli e scrostatori ad aghi

Hammers and needle scalers

92 - 97

Utensili da taglio

Cutting tools

98 - 101

Rivettatrici

Riveting guns

102 - 105

Utensili vari

Various tools

106 - 111

Sollevatori

Jacks

112 - 119

Kit & Accessori

Kits & accessories

120 - 125

Occhiali

Glasses

126 - 127

Indice alfanumerico

Alphanumeric index

MASTER 65

Avvitatore 1" con motore a scoppio
1" self propelled impact wrench





MASTER 65

CAPACITÀ DI SERRAGGIO

Attacco quadro:	1"
Capacità bullone:	da 16 a 32 mm
Capacità serraggio massima:	2500 Nm
Coppia di utilizzo consigliata:	500-1800 Nm

SISTEMA AD IMPULSI

Tipo:	camma e sfera
Impatti al minuto:	1800

MOTORE

Cilindrata:	63 cc
-------------	-------

LIVELLO SONORO

Livello pressione acustica (LpA)	101,7 dBA (ISO 3744)
Livello potenza acustica (LwA)	114,8 dBA (ISO 3744)

LIVELLO VIBRAZIONI

	12,2 m/s ² (ISO 5349)
--	----------------------------------

DIMENSIONI

Lunghezza escluso quadro:	602 mm
Altezza:	284 mm
Larghezza:	452 mm
Peso senza carburante:	17,7 kg



TROLLEY

CARRELLO PER SUPPORTO MASTER 65

E' stato progettato da utilizzare con l'avvitatore ad impulsi mod. MASTER 65.

Il carrello é fornito completo di due accessori per permettere di utilizzare l'avvitatore sia in posizione verticale, che orizzontale.

L'uso del carrello col Master 65 e gli accessori permette di ridurre il lavoro manuale, ne facilita l'utilizzo, migliora il confort dell'operatore e quindi migliora la produttività.



CARATTERISTICHE

Braccio regolabile per uso con attrezzi di peso differenti. Semplice freno ruote.

Può essere montato e smontato in pochi minuti, senza l'utilizzo di utensili.

Il corpo principale può essere bloccato per facilitarne il trasporto.

Ruote isolate. Può essere inclinato di 5°.

Quando è smontato, risulta facile da trasportare nel baule di una utilitaria.



ACCESSORI

28017550 Kit per utilizzo verticale



28017560 Kit per utilizzo orizzontale



DATI TECNICI

Peso Totale:	30 kg
Base:	17 kg
Ruota:	10 kg
Asta:	3 kg
Lunghezza:	1080 mm
Profondità:	1625 mm
Altezza (aperto):	870 mm
Altezza (chiuso):	440 mm



CASSETTA IN METALLO Cod. 17500582

Robusto contenitore completo di coperchio con cerniera, serratura con possibilità di inserire un lucchetto e comodi ganci laterali. Può contenere in 3 vani separati l'avvitatore, gli attrezzi di dotazione e gli accessori.

Dimensioni: 590 x 455 x 290 mm

Peso: 16 kg

ALTRI ACCESSORI

Chiavi a bussola esagonali in versione corta o lunga:	
10806038	Bussola 1" x 38
10806046	Bussola 1" x 46
10807038	Bussola 1" x 38 lunga
10807041	Bussola 1" x 41 lunga
10807046	Bussola 1" x 46 lunga
Chiavi a bussola speciali per uso ferroviario:	
10817120	Bussola 1" x 21 x 21
10817121	Bussola 1" x 21 x 28
10817124	Bussola 1" x 24 x 24
Altri accessori disponibili:	
10550000	Kit trattenitore 1"
10820006	Snodo da 1"
10830604	Prolunga 1" x 175 mm
10830606	Prolunga 1" x 250 mm

APPLICAZIONE A FORARE

Mandrino con inserimento punte a cambio rapido. Si applica come una normale chiave a bussola sul Master 65, trasformando l'avvitatore in trapano per legno. Il cambio rapido permette di sostituire in pochi secondi le punte, senza l'ausilio di chiavi supplementari. Le punte da legno con attacco esagonale di 9 mm sono disponibili con diametro 16 e 18 mm.

Cod. 17800090

Mandrino 1" a cambio rapido attacco esagonale 9 mm

Cod. 11109016

Punta a forare attacco esagonale \varnothing 16 mm

Cod. 11109018

Punta a forare attacco esagonale \varnothing 18 mm



AIRTEC
IMPACTOR 1/2
NO. 400 IN 19030503
CE
2010

AIRTEC
TOOLS

3 2 1 1 2 3
R

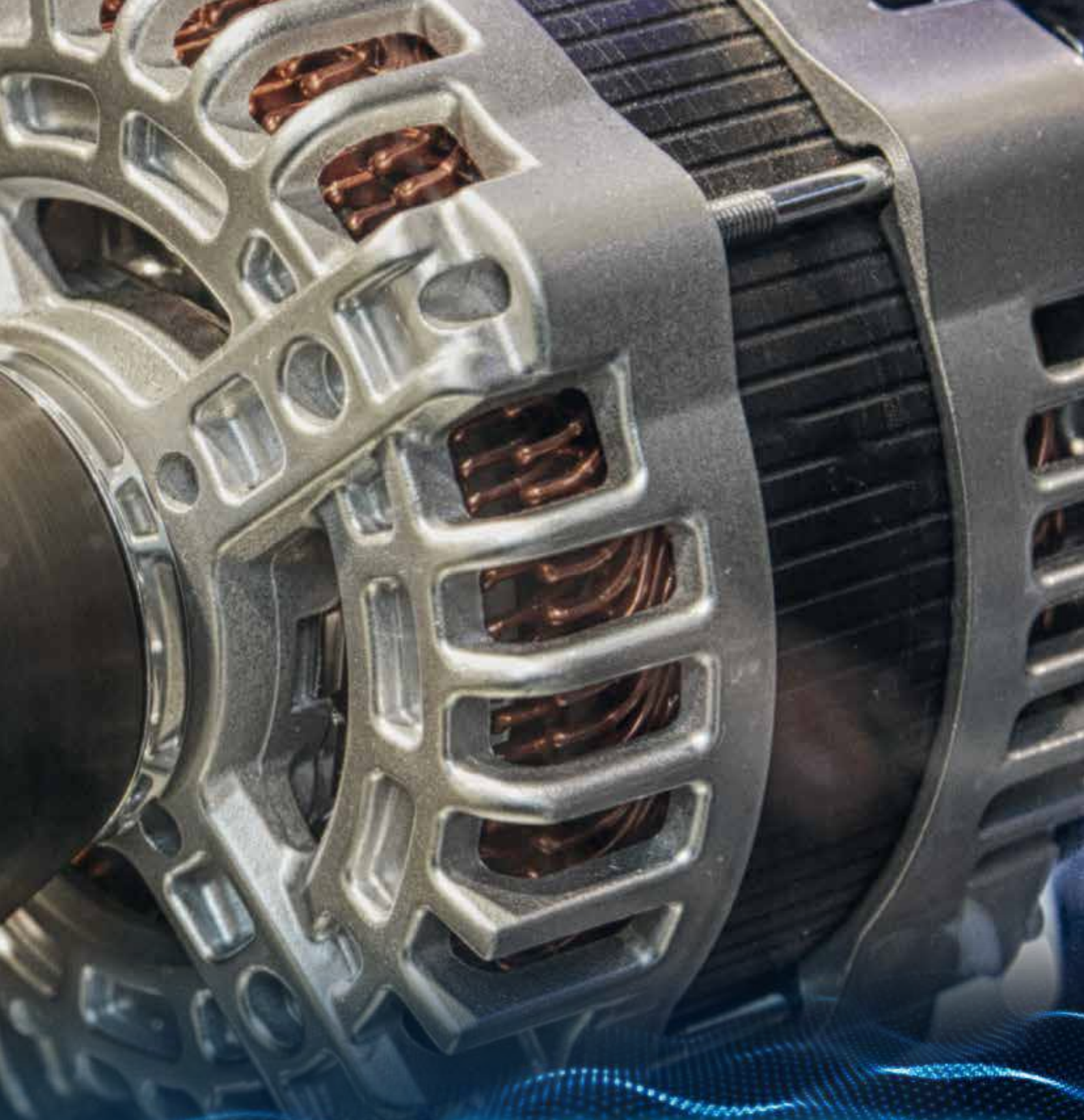

AVVITATORI AD IMPULSI

Impact wrenches lines

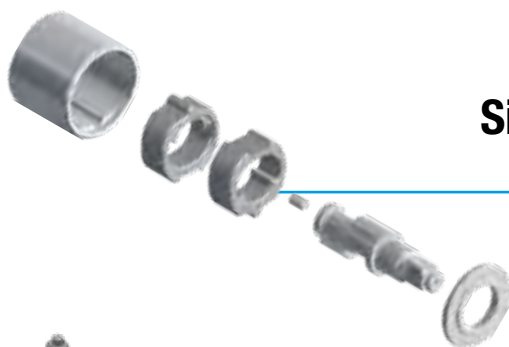

Sistema ad impulsi Mechoneer

MECHONEER IMPACT SYSTEM

352 - 355 - 357 - 357 LL
358 - 358 LL - 359D - 359D LL

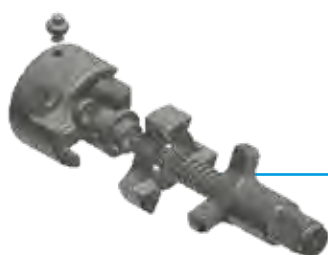

Sistema ad alzata di camma

3 JAWS MECHANISM

AT 10/2



Sistema a martello singolo

ROCKING DOG MECHANISM

490/P - 491/P - 580



Sistema singolo martello Jumbo

JUMBO HAMMER MECHANISM

301 - 372 - 458 - 472



Sistema a pernetti

PIN CLUTCH MECHANISM

453

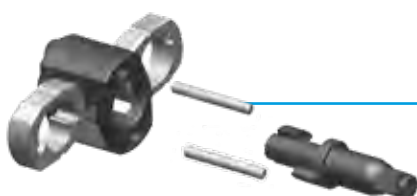

Sistema a doppia massa battente

TWIN HAMMER MECHANISM

310 - 315 - 320 - 333
457 - 462 - 466 - 814D - 814D LL
815 - 815 LL

IMPACT WRENCHES LINE

MECHONEER



Il sistema MECHONEER è un meccanismo IBRIDO che combina i sistemi di battuta TWIN HAMMER e PIN-LESS, con meno parti mobili, riducendo le vibrazioni e l'usura. La parte posteriore dell'albero è collegata da un albero secondario allo stelo del rotore, garantendo concentricità e allineamento tra rotore, coperchio e cilindro, riducendo vibrazioni ed usura ed eliminando perdite d'aria interne del motore, che potrebbero causare perdite di potenza.

The patented MECHONEER drive system is a HYBRID TWIN HAMMER/PIN-LESS mechanism that has fewer moving parts, reducing vibration and wear. The rear of the anvil is connected by a secondary spindle to the rotor spline of the motor, guaranteeing concentricity and alignment of rotor, end plates and cylinder – reducing wear and eliminating internal motor air leaks, which can affect power.

- A.** Il coperchio della gabbia mantiene il grasso nei martelli e nella gabbia, riducendo l'usura.
- B.** Il meccanismo MECHONEER, pin-less/twin hammer, riduce usura e vibrazioni.
- C.** Lo stelo del rotore collegato all'albero elimina il disallineamento e riduce l'usura e le vibrazioni.
- D.** Il pulsante brevettato, che combina il comando avvitatura/svitatura/gestione della potenza, offre una comoda operazione con una mano.
- E.** Il silenziatore brevettato riduce il livello di rumorosità a 85 dB(A).
- F.** L'impugnatura ergonomica offre grande comfort all'operatore.
- G.** La struttura dell'assemblaggio del motore con bullone passante elimina il disallineamento dei componenti, riducendo l'usura, ed elimina le perdite d'aria del motore, aumentando le prestazioni.

- A.** Hammer cage end plate retains the grease in the hammers & cage, reducing wear.
- B.** MECHONEER pin-less/twin hammer clutch reduces wear and vibration.
- C.** Rotor spline connected to anvil eliminates misalignment and reduces wear and vibration.
- D.** Patented trigger mounted combined forward/reverse/power management switch provides convenient one hand operation.
- E.** Patented muffler reduces noise level to 85 dB(A).
- F.** Ergonomic handle design provides unmatched operator comfort.
- G.** Through-bolt motor assembly construction eliminates component misalignment reducing wear, and eliminates motor air leakage increasing performance.

Il coperchio è sigillato con la gabbia, evitando le perdite di grasso.

The end plate seals with the cage, preventing loss of grease.

L'albero è guidato da un doppio battente, secondo il concetto twin hammer.

The anvil is driven by the twin hammers "twin hammer concept".

I battenti sono guidati dalla gabbia, secondo il concetto pin-less.

The hammers are driven by the cage "pin-less concept".

La gabbia è guidata dallo stelo del rotore, secondo il concetto pin-less.

The cage is driven by the rotor spline "pin-less concept".



Il perno si innesta sia in un foro sul retro dell'albero che in un foro nella parte anteriore dello stelo del rotore, assicurando una perfetta concentricità tra il rotore e l'albero MECHONEER.

The pin engages in a hole at the back of the anvil and also engages in a hole at the front of the rotor spline ensuring perfect concentricity between the rotor and MECHONEER anvil.

SISTEMA BATTENTE DRIVE SYSTEM

MOD. 580

Cod. 16405000

€ 240,00



Avvitatore a impulsi da 1/4", a bassa coppia di serraggio, indicato per la rimozione delle candele di preriscaldamento. Kit completo di snodo 1/4", 2 prolunghe 1/4" (50 & 100 mm) e 5 bussole 1/4" (8 - 9 - 10 - 11 - 12 mm).

Low torque 1/4" impact wrench, for diesel glow plug removal. The set includes 1/4" universal joint, 2 pcs 1/4" extension bars (50 & 100 mm) and 5 pcs 1/4" impact sockets (8 - 9 - 10 - 11 - 12 mm).

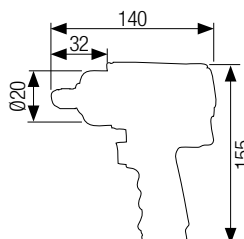

"	Nm	bar	mm	l/sec.	kg	dB(A)	dB(A)	m/sec ²		
1/4	10-40	10.000	6,2	1/4" BSPT	8	2,5	0,80	87±3	98±3	5,1

MOD. 491/P

Cod. 12101011

€ 180,00



Avvitatore ad impulsi con attacco da 3/8". Avvitatore leggero del tipo a presa diretta, dotato di regolatore a più posizioni.

3/8" light straight impact wrench, equipped with air regulator.



"	mm	Nm	Nm	bar	mm	l/sec.	kg	dB(A)	dB(A)	m/sec ²		
3/8	10	7-90	100	11.000	6,2	1/4" BSPT	8	2,0	0,95	98±3	100±3	<2,5

MOD. 490/P

Cod. 12101015

€ 170,00



Avvitatore ad impulsi con attacco da 3/8", leggero ed ergonomico, con regolatore di potenza progressivo.

3/8" light and ergonomic impact wrench, equipped with progressive regulator.



"	mm	Nm	Nm	bar	mm	l/sec.	kg	dB(A)	dB(A)	m/sec ²		
3/8	10	8-85	100	10.000	6,2	1/4" BSPT	8	2,0	1,20	91±3	103±3	8,9

IMPACT WRENCHES LINES

MOD. 301

Cod. 12101001

€ 250,00

Avvitatore ad impulsi con attacco da 3/8". Utensile dotato di scarico dell'aria nell'impugnatura e regolatore a 5 posizioni per senso di rotazione.

3/8" impact wrench, equipped with air exhaust through the handle and air regulator with 5 positions for direction of rotation.



Icon	mm	Nm	Nm	bar	mm	l/sec.	kg	dB(A)	dB(A)	m/sec ²		
3/8"	14	7-120	271	10.000	6,2	1/4" BSPT	10	1,2	1,35	93±3	104±3	6,6

MOD. 310

Cod. 12101025

€ 240,00

Avvitatore ad impulsi professionale 3/8" in composito. Eccellente rapporto peso/potenza. Utensile leggero ed ergonomico, con scarico dell'aria nell'impugnatura, regolatore a 3 posizioni per senso di rotazione e attacco aria girevole.

Professional 3/8" impact wrench with composite body. Excellent weight to power ratio. Very lightweight and ergonomic tool, equipped with air exhaust through the handle, air regulator with 3 positions for direction of rotation and swivel air inlet.



Icon	mm	Nm	Nm	bar	mm	l/sec.	kg	dB(A)	dB(A)	m/sec ²		
3/8"	12	34-338	583	11.000	6,2	1/4" BSPT	8	2,0	1,20	84±3	95±3	6,8

MOD. 352

Cod. 12102052

€ 290,00

Mini avvitatore a impulsi con attacco da 1/2", dotato del nuovo sistema di battuta Mechoneer. Avvitatore notevolmente ergonomico ed estremamente compatto, di buona potenza. Scarico dell'aria nell'impugnatura e regolatore/invertitore nel pulsante, 3 posizioni (2 in avvitamento). **Coppia di sbloccaggio del dado in svitamento 1.200 Nm**

Mini 1/2" impact wrench, equipped with the new Mechoneer drive system. Ergonomic and extremely compact impact wrench, of good power. Exhaust in the handle and air regulator in the trigger with 3 positions (2 tightening positions). **Nut reversing busting torque: 1.200 Nm**



MECHONEER

"	mm	Nm	Nm		bar	mm	l/sec.	kg	dB(A)	dB(A)	m/sec ²	
1/2	20	210-542	750	9.500	6,2	1/4" BSP	10	2,0	1,30	85,1±3	96,1±3	4,3

MOD. 372

Cod. 12102031

€ 320,00

Avvitatore angolare ad impulsi, con attacco da 1/2". Avvitatore estremamente compatto, con impugnatura di adeguata lunghezza per arrivare in posti di lavoro stretti e scomodi. Utensile dotato di scarico dell'aria nell'impugnatura e regolatore a 3 posizioni in avvitamento.

Extremely compact 1/2" angle impact wrench, with adequate handle length to get to narrow and uncomfortable working places. Equipped with air exhaust through the handle and 3 levels air regulator on screwing.



"	mm	Nm	Nm		bar	mm	l/sec.	kg	dB(A)	dB(A)	m/sec ²	
1/2	14	27-231	325	8.500	6,2	1/4" BSPT	10	2,6	1,16	92,2±3	103,2±3	9,9

IMPACT WRENCHES LINES

MOD. 458

Cod. 12102087

€ 260,00

Avvitatore ad impulsi con attacco da 1/2", notevolmente ergonomico ed estremamente compatto, molto potente. **Utensile dotato di foro per ingrassaggio** nell'albero, scarico dell'aria nell'impugnatura e regolatore a 3 posizioni per senso di rotazione.

Ergonomic and extremely compact very powerful 1/2" impact wrench. **Tool equipped with hole for greasing in the anvil**, air exhaust through the handle and air regulator with 3 positions for direction of rotation.



mod. AC 458

Cod. 10700458

€ 22,00

Ingrassatore per utensili pneumatici.
Tubetto da 100 g.

Grease gun for air tool maintenance. 100 g
lubrication grease.



mod. AC 458/R

Cod. 10700459

€ 12,00

Tubetto grasso da 100 g.
100 g lubrication grease.

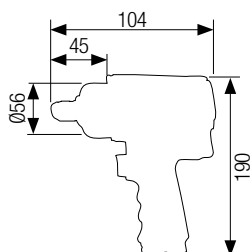

Icon	mm	Nm	Nm	bar	mm	l/sec.	kg	dB(A)	dB(A)	m/sec ²		
1/2"	20	244-542	949	10.000	6,2	1/4"BSPT	10	2,3	1,37	94,3±3	105,3±3	7,2

MOD. 355

Cod. 12102055

€ 390,00

Avvitatore a impulsi con attacco da 1/2", dotato del nuovo sistema di battuta Mechoneer. Scarico dell'aria nell'impugnatura e regolatore/invertitore nel pulsante, a 3 posizioni (2 in avvitamento). **Coppia di sbloccaggio del dado in svitamento 1.850 Nm**

1/2" impact wrench, equipped with the new Mechoneer drive system. The exhaust in the handle and air regulator in the trigger with 3 positions (2 tightening positions). **Nut reversing busting torque: 1.850 Nm**

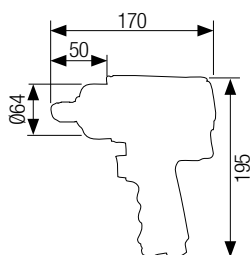

MECHONEER

"	mm	Nm	Nm		bar	mm	l/sec.	kg	dB(A)	dB(A)	m/sec ²	
1/2	22	130-650	1.230	7.500	6,2	1/4" BSP	10	2,7	2,00	84,7±3	95,7±3	6,5

MOD. 315

Cod. 12102015

€ 300,00

Avvitatore ad impulsi professionale 1/2" in composito. Eccellente rapporto peso/potenza. Utensile leggero ed ergonomico, con scarico dell'aria nell'impugnatura, regolatore a 3 posizioni per senso di rotazione e attacco aria girevole.

Professional 1/2" impact wrench with composite body. Excellent weight to power ratio. Very lightweight and ergonomic tool, equipped with air exhaust through the handle, air regulator with 3 positions for direction of rotation and swivel air inlet.

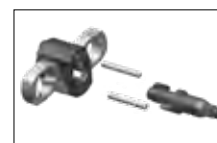
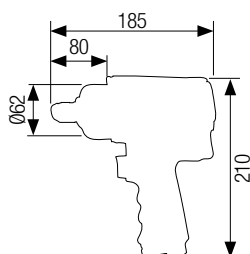

MOD. 315/K

Cod. 12102014

€ 330,00

Mod. 315 in valigetta, completa di bussole 1/2" (17 - 19 - 21 mm) e bussole lunghe rivestite 1/2" (17 - 19 - 21 mm).

Mod. 315 in blow mould case, with 1/2" sockets (17 - 19 - 21 mm) and 1/2" deep sockets with plastic cover (17 - 19 - 21 mm).



"	mm	Nm	Nm		bar	mm	l/sec.	kg	dB(A)	dB(A)	m/sec ²	
1/2	18	68-786	1.112	7.000	6,2	1/4" BSPT	10	2,0	1,95	92±3	103±3	6,8

IMPACT WRENCHES LINES

MOD. 457

Cod. 12102084

€ 355,00

Avvitatore a impulsi da 1/2", notevolmente ergonomico ed estremamente compatto, molto potente. Utensile dotato di scarico dell'aria nell'impugnatura e regolatore/invertitore a 3 posizioni per senso di rotazione.

Very powerful ergonomic and extremely compact 1/2" impact wrench. Equipped with air exhaust through the handle and air regulator with 3 positions for direction of rotation.

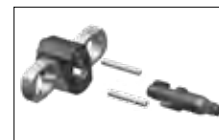
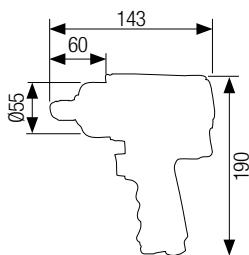

Socket Size	Socket Length	Max Torque	Min Torque	Speed	Pressure	Socket Size	Socket Length	Weight	Sound Power	Sound Pressure	Vibration	
"	mm	Nm	Nm	rpm	bar	"	mm	kg	dB(A)	dB(A)	m/sec ²	
1/2	22	220-600	1.356	9.000	6,2	1/4" BSPT	10	3,3	1,80	93,1±3	104,1±3	2,8

MOD. 453

Cod. 12102076

€ 190,00

Avvitatore ad impulsi con attacco da 1/2". Scarico dell'aria nell'impugnatura. Regolatore di potenza a 4 posizioni in avvitamento.

1/2" impact wrench. Air exhaust through the handle. The air regulator has 4 positions when screwing.

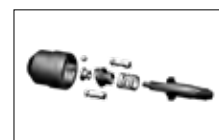
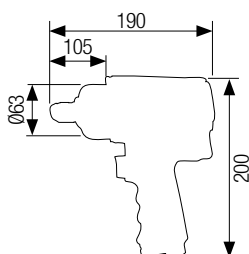

MOD. 453/K Cod. 12102077 € 240,00

Mod. 453 in valigetta, completa di bussole 1/2" (9-10-11-13-14-17-19-22-24-27 mm), prolunga 125 mm, chiave esagonale 4 mm, raccordo, mini oliatore e contenitore d'olio.

Mod. 453 in blow mould case, with 1/2" sockets (9-10-11-13-14-17-19-22-24-27 mm), 125 mm extension bar, 4 mm hexagonal key wrench, nipple, mini oiler and oil pot.



Socket Size	Socket Length	Max Torque	Min Torque	Speed	Pressure	Socket Size	Socket Length	Weight	Sound Power	Sound Pressure	Vibration	
"	mm	Nm	Nm	rpm	bar	"	mm	kg	dB(A)	dB(A)	m/sec ²	
1/2	16	34-420	516	7.800	6,2	1/4" BSPT	8	1,5	2,40	86,1±3	99,1±3	<2,5

MOD. 333

Cod. 12102050

€ 340,00

Avvitatore ad impulsi 1/2" molto potente. **Raggiunge una coppia di sbloccaggio del dado di 1830 Nm.** Utensile dotato di scarico dell'aria nell'impugnatura, regolatore a 3 livelli in avvitamento e attacco aria girevole.

Very powerful 1/2" impact wrench. **Nut busting torque of 1830 Nm.** Equipped with exhaust through the handle, 3 levels regulator on screwing and swivel air connection.

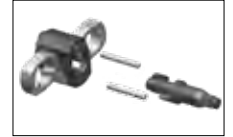
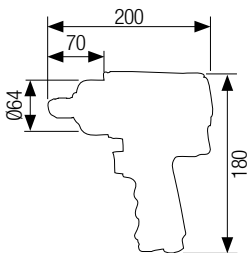

"	mm	Nm	Nm		bar	mm	l/sec.	kg	dB(A)	dB(A)	m/sec ²
1/2	22	130-610	1.220	7.500	6,2	1/4" BSP	10	2,10	84,3±3	95,3±3	6,1

MOD. 462

Cod. 12102045

€ 260,00

Avvitatore ad impulsi con attacco da 1/2". Scarico aria nell'impugnatura. Dotato di regolatore di potenza a 4 livelli in entrambi i sensi di rotazione.

1/2" impact wrench. Air exhaust through the handle. Equipped with a 4 levels air regulator in both directions of rotations.

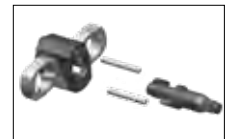
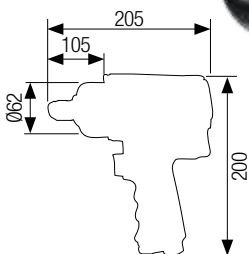

MOD. 462/K Cod. 12102044 € 310,00

Mod. 462 in valigetta, completa di bussole 1/2" (17 - 19 - 21 mm) e bussole lunghe rivestite 1/2" (17 - 19 - 21 mm).

Mod. 462 in blow mould case, with 1/2" sockets (17 - 19 - 21 mm) and 1/2" deep sockets with plastic cover (17 - 19 - 21 mm).



"	mm	Nm	Nm		bar	mm	l/sec.	kg	dB(A)	dB(A)	m/sec ²
1/2	16	55-420	500	7.000	6,2	1/4" BSPT	10	3,0	92±3	101±3	4,1

IMPACT WRENCHES LINES

MOD. 357

Cod. 12103067

€ 810,00

Avvitatore a impulsi con attacco da 3/4", dotato del nuovo sistema di battuta Mechoneer. Scarico dell'aria nell'impugnatura e regolatore/invertitore nel pulsante, a 3 posizioni (2 in avvitamento). **Coppia di sbloccaggio del dado in svitamento 2.600 Nm**

3/4" impact wrench, equipped with the new Mechoneer drive system. The exhaust in the handle and air regulator in the trigger with 3 positions (2 tightening positions). **Nut reversing busting torque: 2.600 Nm**

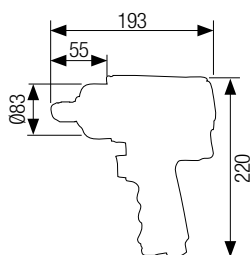

MECHONEER



"	mm	Nm	Nm		bar	mm	l/sec.	kg	dB(A)	dB(A)	m/sec ²	
3/4	32	270-1.860	2.200	5.500	6,2	3/8" BSP	10	3,7	3,50	85,6±3	96,6±3	7,7

MOD. 357 LL

Cod. 12103068

€ 885,00

Avvitatore a impulsi ad albero lungo, con attacco da 3/4", dotato del nuovo sistema di battuta Mechoneer. Scarico dell'aria nell'impugnatura e regolatore/invertitore nel pulsante, a 3 posizioni (2 in avvitamento). **Coppia di sbloccaggio del dado in svitamento 2.600 Nm**

3/4" long anvil impact wrench, equipped with the new Mechoneer drive system. The exhaust in the handle and air regulator in the trigger with 3 positions (2 tightening positions). **Nut reversing busting torque: 2.600 Nm**

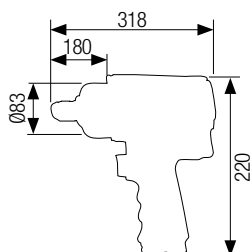

MECHONEER



"	mm	Nm	Nm		bar	mm	l/sec.	kg	dB(A)	dB(A)	m/sec ²	
3/4	32	270-1.860	2.200	5.500	6,2	3/8" BSP	10	3,7	4,00	85,6±3	96,6±3	7,7

MOD. 466

Cod. 12103052

€ 500,00

Avvitatore ad impulsi 3/4" molto leggero. Utensile dotato di scarico dell'aria nell'impugnatura e regolatore a 3 livelli per senso di rotazione.

Very lightweight 3/4" impact wrench. Equipped with exhaust through the handle and 3 levels regulator for direction of rotation.

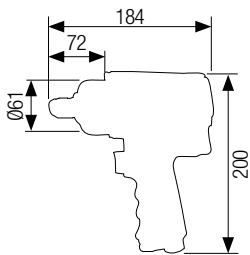

"	mm	Nm	Nm	bar	mm	l/sec.	kg	dB(A)	dB(A)	m/sec ²		
3/4	27	380-1.050	1.491	7.200	6,2	1/4" BSPT	10	2,8	2,65	87±3	98±3	4,5

MOD. 320

Cod. 12103040

€ 620,00

Avvitatore ad impulsi professionale 3/4" in composito. Eccellente rapporto peso/potenza. Utensile leggero ed ergonomico, con scarico dell'aria nell'impugnatura, regolatore a 3 posizioni per senso di rotazione e attacco aria girevole.

Professional 3/4" impact wrench with composite body. Excellent weight to power ratio. Very lightweight and ergonomic tool, equipped with air exhaust through the handle, air regulator with 3 positions for direction of rotation and swivel air inlet.

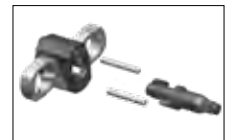
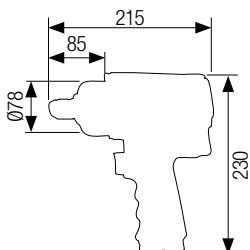

"	mm	Nm	Nm	bar	mm	l/sec.	kg	dB(A)	dB(A)	m/sec ²		
3/4	27	271-1.627	2.034	5.500	6,2	3/8"BSPT	13	4,3	3,30	92,5±3	103,5±3	11,2

IMPACT WRENCHES LINES

MOD. 358

mod. 358 Cod. 12106083

€ 1.240,00

Avvitatore a impulsi, con attacco da 1", dotato del nuovo sistema di battuta Mechoneer. Scarico dell'aria nell'impugnatura e regolatore/invertitore nel pulsante, a 3 posizioni (2 in avvitamento). Maniglia laterale in dotazione.
Coppia di sbloccaggio del dado in svitamento 3.120 Nm

1" impact wrench, equipped with the new Mechoneer drive system. The exhaust in the handle and air regulator in the trigger with 3 positions (2 tightening positions). Side handle included.
Nut reversing busting torque: 3.120 Nm



MECHONEER



"	mm	Nm	Nm	bar	mm	l/sec.	kg	dB(A)	dB(A)	m/sec ²		
1	39	1.800-2.712	2.983	4.300	6,2	1/2"BSP	13	5,0	6,80	102,8±3	124,5±3	8,8

MOD. 358 LL

Cod. 12106084

€ 1.300,00

Avvitatore a impulsi ad albero lungo, con attacco da 1", dotato del nuovo sistema di battuta Mechoneer. Scarico dell'aria nell'impugnatura e regolatore/invertitore nel pulsante, a 3 posizioni (2 in avvitamento). Maniglia laterale in dotazione.
Coppia di sbloccaggio del dado in svitamento 3.120 Nm

1" long anvil impact wrench, equipped with the new Mechoneer drive system. The exhaust in the handle and air regulator in the trigger with 3 positions (2 tightening positions). Side handle included.
Nut reversing busting torque: 3.120 Nm



MECHONEER



"	mm	Nm	Nm	bar	mm	l/sec.	kg	dB(A)	dB(A)	m/sec ²		
1	39	1.800-2.712	2.983	4.300	6,2	1/2"BSP	13	5,0	7,50	102,8±3	124,5±3	8,8

MOD. 815

Cod. 12106070

€ 1.130,00



Avvitatore ad impulsi 1". Scarico dell'aria nell'impugnatura e regolatore di potenza a 3 livelli in avvitamento.

1" impact wrench. Air exhaust through the handle and 3 levels air regulator on screwing.

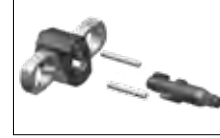

"	mm	Nm	Nm		bar	mm	l/sec.	kg	dB(A)	dB(A)	m/sec ²	
1	33	700-2.100	2.712	5.000	6,2	1/2" BSPT	16	4,2	7,40	102±3	113±3	14,9

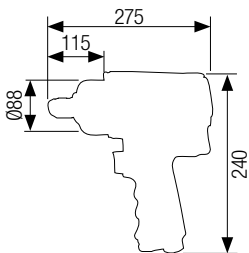
**MOD. 815P**

Cod. 12106070P

€ 1.130,00

Utensile predisposto per carrello silenziato.

Tool fitted for silenced trolley.

"	mm	Nm	Nm		bar	mm	l/sec.	kg	dB(A)	dB(A)	m/sec ²
1	33	700-2.100	2.712	5.000	6,2	1/2" GAS	4,2	7,40	102±3	113±3	14,9

MOD. 815 LL

Cod. 12106075

€ 1.170,00



Avvitatore ad impulsi 1" con albero prolungato 6". Scarico dell'aria nell'impugnatura e regolatore di potenza a 3 livelli in avvitamento.

1" impact wrench with 6" long anvil. Air exhaust through the handle and 3 levels air regulator on screwing.

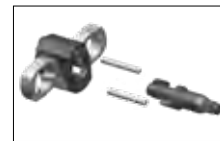

"	mm	Nm	Nm		bar	mm	l/sec.	kg	dB(A)	dB(A)	m/sec ²	
1	33	700-2.100	2.712	5.000	6,2	1/2" BSPT	16	4,2	8,15	103±3	114±3	14,7

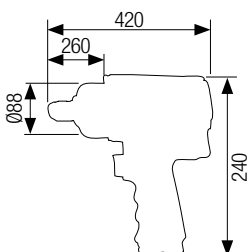
**MOD. 815 LLP**

Cod. 12106075 P

€ 1.170,00

Utensile predisposto per carrello silenziato.

Tool fitted for silenced trolley.

"	mm	Nm	Nm		bar	mm	l/sec.	kg	dB(A)	dB(A)	m/sec ²
1	33	700-2.100	2.712	5.000	6,2	1/2" GAS	4,2	8,15	103±3	114±3	14,7

IMPACT WRENCHES LINES

MOD. 359D

Cod. 12106086

€ 1.300,00

Avvitatore a impulsi dritto con attacco da 1", dotato del nuovo sistema di battuta Mechoneer. Scarico dell'aria inferiore. Il regolatore/invertitore è a 3 posizioni per senso di rotazione. **Coppia di sbloccaggio del dado in svitamento 3.390 Nm.**

Straight 1" impact wrench, equipped with the new Mechoneer drive system. The exhaust is at the bottom. The air regulator has 3 positions in both directions of rotation. **Nut reversing busting torque: 3.390 Nm**



NEW



MECHONEER

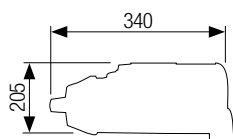

"	mm	Nm	Nm		bar	mm	l/sec.	kg	dB(A)	dB(A)	m/sec ²
1	42	1.100-2.800	3.200	6.000	6,2	1/2" BSP	13	5,7	102,9 ± 3	113,9 ± 3	12,7

MOD. 359D LL

Cod. 12106087

€ 1.380,00

Avvitatore a impulsi dritto ad albero lungo, con attacco da 1", dotato del nuovo sistema di battuta Mechoneer. Scarico dell'aria inferiore. Il regolatore/invertitore è a 3 posizioni per senso di rotazione. **Coppia di sbloccaggio del dado in svitamento 3.390 Nm.**

Straight 1" long anvil impact wrench, equipped with the new Mechoneer drive system. The exhaust is at the bottom. The air regulator has 3 positions in both directions of rotation. **Nut reversing busting torque: 3.390 Nm**



NEW



MECHONEER

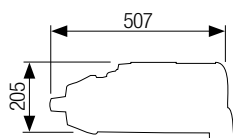

"	mm	Nm	Nm		bar	mm	l/sec.	kg	dB(A)	dB(A)	m/sec ²
1	42	1.100-2.800	3.200	6.000	6,2	1/2" BSP	13	5,7	102,9 ± 3	113,9 ± 3	12,7

MOD. 814D

Cod. 12106067

€ 1.200,00

Avvitatore ad impulsi 1" con impugnatura posteriore. Scarico dell'aria laterale (per uso previsto con impugnatura orizzontale). Regolatore di potenza a 3 livelli per ogni senso di rotazione e pulsante a doppia azione per evitare azionamenti bruschi.

1" straight impact wrench. Side air exhaust (for use with horizontal handle). 3 levels air regulator in both directions of rotation and double action button to avoid abrupt operation.

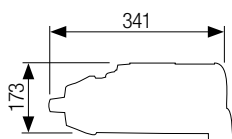

"	mm	Nm	Nm	bar	mm	l/sec.	kg	dB(A)	dB(A)	m/sec ²		
1	39	271-2.983	3.390	5.000	6,2	3/8" BSPT	13	4,6	6,50	100,6±3	111,6±3	14,1

MOD. 814D LL

Cod. 12106068

€ 1.300,00

Avvitatore ad impulsi 1" con impugnatura posteriore ed albero prolungato 6". Scarico dell'aria laterale (per uso previsto con impugnatura orizzontale). Regolatore di potenza a 3 livelli per ogni senso di rotazione e pulsante a doppia azione per evitare azionamenti bruschi.

1" straight impact wrench with 6" long anvil. Side air exhaust (for use with horizontal handle). 3 levels air regulator in both directions of rotation and double action button to avoid abrupt operation.

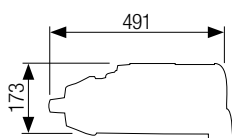

"	mm	Nm	Nm	bar	mm	l/sec.	kg	dB(A)	dB(A)	m/sec ²		
1	39	271-2.983	3.390	5.000	6,2	3/8" BSPT	13	4,6	7,40	100,6±3	111,6±3	14,1

IMPACT WRENCHES LINES

MOD. AT10/2

Cod. 12007030

€ 4.400,00



MADE IN ITALY

Avvitatore di elevate prestazioni, con attacco da 1 1/2" e impugnatura posteriore, per lavori gravosi. Scarico dell'aria frontale. Equipaggiata con maniglia laterale e gancio di sospensione rimovibili.

High performance 1 1/2" impact wrench with "D" handle for heavy-duty jobs. Front exhaust. Equipped with detachable side handle and suspension hook.



Icon	mm	Nm	Nm	bar	mm	l/sec.	kg	dB(A)	dB(A)	m/sec ²		
1 1/2"	24-56	1.318-3.296	5.933	3.200	6,2	1/2"GAS	16	6,7	14,5	104,1±3	109,6±3	12,3

	Mod.	Cod.													
			"	mm	Nm	Nm		bar		mm	l/sec.	kg	dB(A)	dB(A)	m/sec ²
	580	16405000	1/4	-	10-40	-	10.000	6,2	1/4" BSPT	8	2,5	0,80	87±3	98±3	5,1
	491/P	12101011	3/8	10	7-90	100	11.000	6,2	1/4" BSPT	8	2,0	0,95	98±3	100±3	<2,5
	490/P	12101015	3/8	10	8-85	100	10.000	6,2	1/4" BSPT	8	2,0	1,20	91±3	103±3	8,9
	301	12101001	3/8	14	7-120	271	10.000	6,2	1/4" BSPT	10	1,2	1,35	93±3	104±3	6,6
	310	12101025	3/8	12	34-338	583	11.000	6,2	1/4" BSPT	8	2,0	1,20	84±3	95±3	6,8
	352	12102052	1/2	20	210-542	750	9.500	6,2	1/4" BSP	10	2,0	1,30	85,1±3	96,1±3	4,3
	372	12102031	1/2	14	27-231	325	8.500	6,2	1/4" BSPT	10	2,6	1,16	92,2±3	103,2±3	9,9
	458	12102087	1/2	20	244-542	949	10.000	6,2	1/4" BSPT	10	2,3	1,37	94,3±3	105,3±3	7,2
	355	12102055	1/2	22	130-650	1.230	7.500	6,2	1/4" BSP	10	2,7	2,00	84,7±3	95,7±3	6,5
	315	12102015	1/2	18	68-786	1.112	7.000	6,2	1/4" BSPT	10	2,0	1,95	92±3	103±3	6,8
	457	12102084	1/2	22	220-600	1.356	9.000	6,2	1/4" BSPT	10	3,3	1,80	93,1±3	104,1±3	2,8
	453	12102076	1/2	16	34-420	516	7.800	6,2	1/4" BSPT	8	1,5	2,40	86,1±3	99,1±3	<2,5
	333	12102050	1/2	22	130-610	1.220	7.500	6,2	1/4" BSP	10	2,0	2,10	84,3±3	95,3±3	6,1
	462	12102045	1/2	16	55-420	500	7.000	6,2	1/4" BSPT	10	3,0	2,50	92±3	101±3	4,1

IMPACT WRENCHES LINES

	Mod.	Cod.													
			"	mm	Nm	Nm		bar		mm	l/sec.	kg	dB(A)	dB(A)	m/sec ²
	357	12103067	3/4	32	270-1.860	2.200	5.500	6,2	3/8" BSP	10	3,7	3,50	85,6±3	96,6±3	7,7
	357 LL	12103068	3/4	32	270-1.860	2.200	5.500	6,2	3/8" BSP	10	3,7	4,00	85,6±3	96,6±3	7,7
	466	12103052	3/4	27	380-1.050	1.491	7.200	6,2	1/4" BSPT	10	2,8	2,65	87±3	98±3	4,5
	320	12103040	3/4	27	271-1.627	2.034	5.500	6,2	3/8" BSPT	13	4,3	3,30	92,5±3	103,5±3	11,2
	358	12106083	1	39	1.800-2.712	2.983	4.300	6,2	1/2" BSP	13	5,0	6,80	102,8±3	124,5±3	8,8
	358 LL	12106084	1	39	1.800-2.712	2.983	4.300	6,2	1/2" BSP	13	5,0	7,50	102,8±3	124,5±3	8,8
	815	12106070	1	33	700-2.100	2.712	5.000	6,2	1/2" BSPT	16	4,2	7,40	102±3	113±3	14,9
	815 LL	12106075	1	33	700-2.100	2.712	5.000	6,2	1/2" BSPT	16	4,2	8,15	103±3	114±3	14,7
	359D	12106086	1	42	1.100-2.800	3.200	6.000	6,2	1/2" BSP	13	5,7	8,50	102,9±3	113,9±3	12,7
	359D LL	12106087	1	42	1.100-2.800	3.200	6.000	6,2	1/2" BSP	13	5,7	9,50	102,9±3	113,9±3	12,7
	814D	12106067	1	39	271-2.983	3.390	5.000	6,2	3/8" BSPT	13	4,6	6,50	100,6±3	111,6±3	14,1
	814D LL	12106068	1	39	271-2.983	3.390	5.000	6,2	3/8" BSPT	13	4,6	7,40	100,6±3	111,6±3	14,1
	AT10/2	12007030	1 1/2	24-56	1.318-3.296	5.933	3.200	6,2	1/2" GAS	16	6,7	14,5	104,1±3	109,6±3	12,3



BUSSOLE

Impact sockets

1

1/2" IMPACT SOCKETS

Bussole standard

Standard impact sockets



Cod.	mm	€
10802010	10	7,50
10802011	11	7,50
10802012	12	7,50
10802013	13	7,50
10802014	14	7,50
10802015	15	7,50

10802016	16	7,50
10802017	17	7,50
10802018	18	7,50
10802019	19	7,50
10802020	20	9,00
10802021	21	9,00
10802022	22	9,00

10802023	23	9,00
10802024	24	10,00
10802025	25	10,00
10802026	26	12,00
10802027	27	12,00
10802030	30	14,00
10802032	32	15,00

Bussole lunghe

Deep impact sockets



Cod.	mm	€
10803013	13	13,00
10803016	16	14,00
10803017	17	14,00
10803018	18	14,00
10803019	19	14,30

10803021	21	16,70
10803022	22	16,70
10803024	24	17,10
10803027	27	18,00
10803030	30	20,00

Bussole pareti sottili

Thin wall impact sockets



Cod.	mm	€
10813017	17	14,00
10813019	19	14,00
10813021	21	14,00
10813022	22	14,50

Bussole pareti extra sottili

Extra thin wall impact sockets



Cod.	mm	€
10814015	15	17,00
10814017	17	17,00
10814019	19	17,00

Bussole sottili rivestite

Thin wall covered impact sockets



Cod.	mm	€
17970017	17	13,00
17970019	19	13,00
17970021	21	13,00
17970022	22	13,00

1/2" IMPACT SOCKETS

Bussole Torx

Impact Torx sockets



Cod.		€
10850010	E10	10,00
10850011	E11	10,00
10850012	E12	10,00
10850014	E14	10,00
10850016	E16	10,00

10850018	E18	10,00
10850020	E20	11,00
10850022	E22	13,00
10850024	E24	13,00

Bussole inserto Torx

Torx socket bits



Cod.		€
10851030	T30	15,00
10851040	T40	15,00
10851045	T45	15,00
10851050	T50	15,00
10851055	T55	15,00
10851060	T60	15,00

Bussole inserto esagonale

Hexagonal socket bits



Cod.	mm	€
10852008	8	18,00
10852010	10	18,00
10852012	12	18,00
10852014	14	18,00
10852017	17	20,00
10852019	19	20,00

Snodo 1/2"

1/2" universal joint



Cod. 10820002

€ 30,00

Prolunghe

Extensions



Cod.	mm	€
10830204	75	14,00
10830206	125	16,00

Raccordo 1/2"F - 3/4"M

1/2"F - 3/4"M adaptor



Cod. 10840024

€ 14,00

3/4" IMPACT SOCKETS



Bussole standard

Standard impact sockets

Cod.	mm	€
10804017	17	21,00
10804019	19	21,00
10804021	21	21,00
10804022	22	22,00
10804023	23	22,00
10804024	24	22,00
10804025	25	22,00

10804026	26	22,00
10804027	27	22,00
10804028	28	22,00
10804030	30	23,00
10804032	32	23,00
10804033	33	24,00
10804034	34	24,00
10804036	36	26,00

10804038	38	31,00
10804041	41	34,00
10804046	46	35,00



Bussole lunghe

Deep impact sockets

Cod.	mm	€
10805019	19	32,00
10805022	22	32,00
10805024	24	33,00
10805027	27	33,00
10805028	28	33,00
10805030	30	34,50
10805032	32	34,50

10805033	33	37,00
10805034	34	37,00
10805036	36	40,60



Bussole pareti sottili

Thin wall impact sockets

Cod.	mm	€
10815024	24	48,30
10815027	27	48,30
10815030	30	54,50



Snodo 3/4"

3/4" universal joint

Cod. 10820004
€ 60,00



Prolunga

Extension

Cod. 10830404
€ 42,00



Raccordi

Adaptors

Cod.	mm	€
10840042	3/4" F - 1/2" M	24,00
10840046	3/4" F - 1" M	28,00

1" IMPACT SOCKETS

Bussole standard

Standard impact sockets



Cod.	mm	€
10806024	24	32,00
10806027	27	32,00
10806030	30	32,00
10806032	32	32,00
10806033	33	32,00
10806036	36	34,00
10806038	38	38,00

10806039	39	39,00
10806041	41	39,00
10806046	46	44,00
10806050	50	59,00
10806055	55	75,00
10806060	60	80,00
10806065	65	96,00
10806070	70	114,00

Bussole lunghe

Deep impact sockets



Cod.	mm	€
10807024	24	52,00
10807027	27	52,00
10807030	30	52,00
10807032	32	52,00
10807033	33	52,00
10807036	36	54,00

10807038	38	60,00
10807039	39	62,00
10807041	41	64,00
10807046	46	78,00
10807050	50	88,00
10807055	55	110,00
10807060	60	114,00

Bussole pareti sottili

Thin wall impact sockets



Cod.	mm	€
10817027	27	64,00
10817030	30	66,00
10817032	32	66,00

Snodo 1"

1" universal joint



Cod. 10820006
€ 130,00

Prolunghe

Extensions



Cod.	mm	€
10830604	175	58,00
10830606	250	75,00

Raccordo 1"F - 3/4"M

1"F - 3/4"M adaptor



Cod. 10840064
€ 32,00

1 1/2" IMPACT SOCKETS



Bussole standard

Standard impact sockets

Cod.	mm	€
10808050	50	200,00
10808055	55	200,00
10808060	60	220,00
10808065	65	240,00
10808070	70	260,00

10808075	75	290,00
10808080	80	320,00
10808085	85	360,00
10808090	90	410,00
10808095	95	690,00
10808100	100	720,00

10808105	105	800,00
10808110	110	830,00
10808115	115	860,00



Snodo 1 1/2"

1 1/2" universal joint

Cod. 10820008

€ 630,00



Raccordo 1 1/2" F - 1" M

1 1/2" F - 1" M adaptor

Cod. 10840086

€ 220,00



Mod. 500 Cod. 17930000

Kit di chiavi a bussola attacco da 1/2" - Confezione da 10 pezzi.

10 pcs box 1/2" impact sockets.

> 9/10/11/13/14/17/19/22/24/27 mm

€ 56,00



Mod. 505 Cod. 17970000

Set 3 bussole 1/2" pareti sottili con rivestimento in plastica.

3 pcs 1/2" thin wall impact sockets set with plastic cover and insert.

> 17/19/21 mm

€ 30,00



Mod. 506 Cod. 17980000

Set 12 pezzi bussole 1/2" extra corte.

12 pcs. 1/2" Low profile impact socket set

> 10/11/12/13/14/15/16/17/19/21/22/24 mm

€ 50,00



AVVITATORI A CRICCHETTO

Ratchet wrenches





AIRTEC Tools Inc.
Made in USA

DO NOT USE FOR
OVER 300 PSI

AIRTEC
AIRTEC TOOLS

AIRTEC
TOOLS

MOD. 402

Cod. 12301007

€ 170,00

Mini chiave a cricchetto 1/4" reversibile, ideale nell'utilizzo in spazi ridotti. Corpo in composito con scarico posteriore.

1/4" reversible mini ratchet wrench, ideal to work in small spaces. Composite body with rear exhaust.

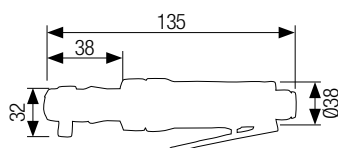

	"	mm	Nm		bar		l/sec.	kg	dB(A)	dB(A)	m/sec ²	
	1/4	8	41	350	6,2	1/4" BSPT	8	2,0	0,50	85±3	96±3	2,6

MOD. 442

Cod. 12301030

€ 180,00

Chiave a cricchetto 1/4" reversibile, ideale per spazi ridotti. Corpo ergonomico in composito con regolatore dell'aria, scarico posteriore e attacco aria girevole.

1/4" reversible ratchet wrench, ideal to work in small spaces. Ergonomic composite body with air regulator, rear exhaust and swivel air inlet.

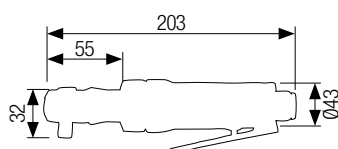

	"	mm	Nm	Nm	bar		l/sec.	kg	dB(A)	dB(A)	m/sec ²		
	1/4	6	7-27	27	200	6,2	1/4" BSPT	8	6,7	0,50	84±3	88±3	1,8

RATCHET WRENCHES

MOD. 401

Cod. 12301006

€ 150,00

Chiave a cricchetto 3/8" reversibile, ideale per utilizzo in spazi ridotti. Corpo in composito con regolatore dell'aria, scarico posteriore e attacco aria girevole.

3/8" reversible ratchet wrench, ideal to work in small spaces. Composite body with air regulator, rear exhaust and swivel air inlet.

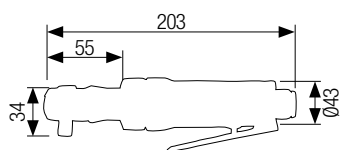

Icon	mm	Nm	Nm	bar	mm	l/sec.	kg	dB(A)	dB(A)	m/sec ²		
3/8"	8	7-41	41	200	6,2	1/4" BSPT	8	6,7	0,50	84±3	88±3	1,8

MOD. 403

Cod. 12301008

€ 170,00

Mini chiave a cricchetto 3/8" reversibile, ideale nell'utilizzo in spazi ridotti. **Albero bombato, per un utilizzo più flessibile, e** corpo in composito con scarico posteriore.

3/8" reversible mini ratchet wrench, ideal to work in small spaces. **Wobble anvil for a more flexible use** and composite body with rear exhaust.

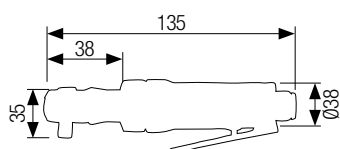

Icon	mm	Nm	Nm	bar	mm	l/sec.	kg	dB(A)	dB(A)	m/sec ²	
3/8"	8	41	350	6,2	1/4" BSPT	8	2,0	0,50	85±3	96±3	2,6

MOD. 441

Cod. 12301021

€ 255,00

Chiave a cricchetto 1/2", con meccanismo ad impulsi che elimina il contraccolpo al serraggio. Corpo in composito. Scarico posteriore e attacco aria girevole.

1/2" reactionless ratchet wrench. Composite body, rear exhaust and swivel air inlet.

**MOD. 441/K**

Cod. 12301022

€ 280,00

Mod. 441 in valigetta con 7 bussole 1/2" (9-10-11-13-14-17-19 mm), uno snodo 1/2", una prolunga 75 mm, 3 inserti L 30 mm, un porta inserti, un contenitore olio e un raccordo.

Mod. 441 in blow mould case, equipped with 7 pcs 1/2" sockets (9-10-11-13-14-17-19 mm), 3 bits L 30 mm, 1/2" universal joint, 75 mm extension bar, bits holder, nipple and oil pot.



"	mm	Nm		bar	mm	l/sec.	kg	dB(A)	dB(A)	m/sec ²	
1/2	10	95	400	6,2	1/4" BSPT	8	5,0	1,30	90±3	96±3	15,3

MOD. 480

Cod. 12301010

€ 140,00

Chiave a cricchetto 1/2" reversibile.

1/2" reversible ratchet wrench.

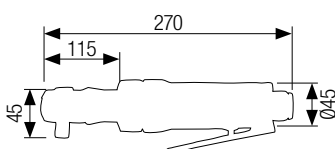

"	mm	Nm	Nm		bar	mm	l/sec.	kg	dB(A)	dB(A)	m/sec ²	
1/2	10	13-60	80	150	6,2	1/4" BSPT	10	9,2	1,20	93±3	105±3	2,5

RATCHET WRENCHES

MOD. 482

Cod. 12101030

€ 240,00

Chiave a cricchetto 1/2" reversibile. Rinforzata e regolabile, ottima affidabilità.

1/2" reversible ratchet wrench. Stronger version, adjustable and very reliable.

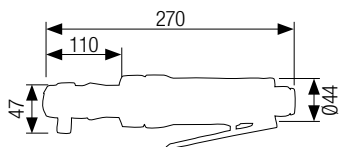

MOD. 482/K

Cod. 12101031

€ 280,00

Mod. 482 in valigetta, con 7 bussole 1/2" (9 - 10 - 11 - 13 - 14 - 17 - 19 mm), 3 inserti L 30 mm, snodo 1/2", prolunga 75 mm, porta inserti, raccordo e contenitore olio.

Mod. 482 in blow mould case, equipped with 7 pcs 1/2" sockets (9 - 10 - 11 - 13 - 14 - 17 - 19 mm), 3 bits L 30 mm, 1/2" universal joint, 75 mm extension bar, bits holder, nipple and oil pot.

Icona	Icona	Icona	Icona	Icona	Icona	Icona	Icona	Icona	Icona	Icona	Icona	Icona
"	mm	Nm	Nm		bar	mm	l/sec.	kg	dB(A)	dB(A)	m/sec ²	
1/2	10	13-115	170	170	6,2	1/4" NPT	8	8,0	1,20	92±3	105±3	3,5

MOD. 472

Cod. 12102032

€ 360,00

Avvitatore angolare ad impulsi 1/2". Comoda testina alta 63 mm per entrare in spazi ridotti. Sistema di battuta a singolo martello Jumbo. Presa ergonomica in composito. Scarico posteriore. Regolatore a 2 livelli in avvitamento, 1 in svitamento.

1/2" angle impact wrench. 63 mm head to work in small spaces. Jumbo hammer mechanism. Ergonomically designed composite handle. Rear exhaust. 2 levels regulator on screwing, 1 on unscrewing.

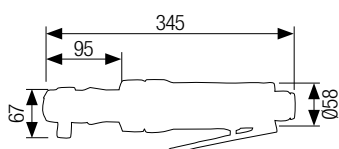

Icona	Icona	Icona	Icona	Icona	Icona	Icona	Icona	Icona	Icona	Icona	Icona	Icona
"	mm	Nm	Nm		bar	mm	l/sec.	kg	dB(A)	dB(A)	m/sec ²	
1/2	16	61-190	244	7.000	6,2	1/4" BSPT	8	2,3	1,80	97±3	108±3	29,2





CACCIAVITI REVERSIBILI

Reversible screwdrivers

REVERSIBLE SCREWDRIVERS

MOD. 630

Cod. 12302030

€ 850,00



Cacciavite reversibile a pistola, con meccanismo di arresto automatico dell'aria (auto shut-off). Dotato di 2 diversi ingressi dell'aria (superiore e inferiore), di gancio superiore e maniglia laterale. Regolazione interna, molto intuitiva e di facile accesso.

Pistol type reversible auto shut-off screwdriver. Equipped with 2 different air inlets (top and bottom), hook and side handle. Intuitive and easy to access internal adjustable clutch.

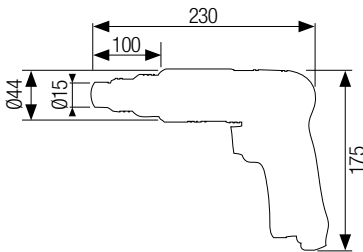

"	mm	Nm		bar	mm	l/sec.	kg	dB(A)	dB(A)	m/sec ²
1/4"E	6	3,0-11,0	500	6,2	1/4" BSPT	10	1,20	77±3	88±3	<2,5

MOD. 632

Cod. 12302032

€ 750,00



Cacciavite reversibile dritto, con meccanismo di arresto automatico dell'aria (auto shut-off). Utensile molto ergonomico, con gancio di sospensione per utilizzo in linee di montaggio. Regolazione interna, molto intuitiva e di facile accesso.

Straight grip reversible auto shut-off screwdriver. Very ergonomic tool with suspension hook for use in assembly lines. Intuitive and easy to access internal adjustable clutch.

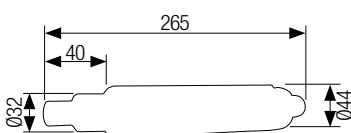

"	mm	Nm		bar	mm	l/sec.	kg	dB(A)	dB(A)	m/sec ²
1/4"E	6	1,5-9,5	550	6,2	1/4" BSPT	10	0,95	78±3	89±3	<2,5

REVERSIBLE SCREWDRIVERS

MOD. 610

Cod. 12302020

€ 500,00

Cacciavite reversibile dritto con arresto automatico dell'aria (auto shut-off). Meccanismo di avviamento a pressione. Frizione regolabile esterna. Fornito con 3 molle per ottenere serraggi diversi. Utensile venduto in configurazione "hard".

Straight grip reversible auto shut-off screwdriver. Push start mechanism. Outside adjustable clutch. Supplied with 3 different springs for adjustment of torque. Tool sold in "hard" configuration.

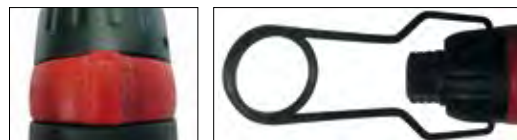

Mod. 610	2 - 5,1 Nm	1 - 4,5 Nm	0,5 - 3,5 Nm
----------	------------	------------	--------------

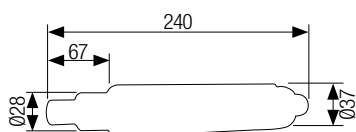

"	mm	Nm	bar	mm	l/sec.	kg	dB(A)	dB(A)	m/sec ²		
1/4"E	5	0,5-5,1	650	6,2	1/4" BSPT	10	7,0	0,60	84±3	93±3	<2,5

MOD. 611

Cod. 12302022

€ 500,00

Cacciavite reversibile a pistola, con meccanismo di arresto automatico dell'aria (auto shut-off). Dotato di 3 diversi ingressi dell'aria (superiore, posteriore e inferiore) e di gancio per utilizzo in linee di montaggio. Fornito con 3 molle per ottenere serraggi diversi. Utensile venduto in configurazione "hard".

Pistol type reversible auto shut-off screwdriver. Equipped with 3 different air inlets (top, rear and bottom) and one hook for use in assembly lines. Supplied with 3 different springs for adjustment of torque. Tool sold in "hard" configuration.



Mod. 611	2 - 5,1 Nm	1 - 4,5 Nm	0,5 - 3,5 Nm
----------	------------	------------	--------------

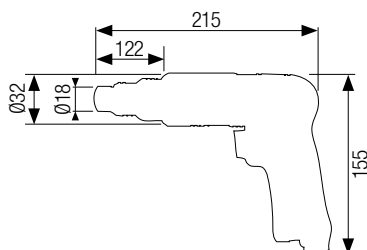

"	mm	Nm	bar	mm	l/sec.	kg	dB(A)	dB(A)	m/sec ²		
1/4"E	5	0,5-5,1	600	6,2	1/4" BSPT	10	2,0	0,83	86,7±3	97,7±3	<2,5

REVERSIBLE SCREWDRIVERS

MOD. 603

Cod. 12301090

€ 350,00

Cacciavite reversibile dritto. Avviamento a leva, scarico posteriore e frizione interna.

Straight reversible screwdriver. Lever start, rear exhaust and inside clutch.

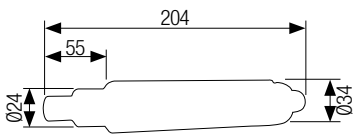

"	mm	Nm		bar	mm	l/sec.	kg	dB(A)	dB(A)	m/sec ²
1/4" E	4	0,3-1,5	1.700	6,2	1/4" NPT	8	5,0	84±3	96±3	4,5

MOD. 606

Cod. 12302010

€ 370,00

Cacciavite reversibile dritto. Avviamento a leva, scarico posteriore e frizione regolabile esterna.

Straight reversible screwdriver. Lever start, rear exhaust and outside adjustable clutch.

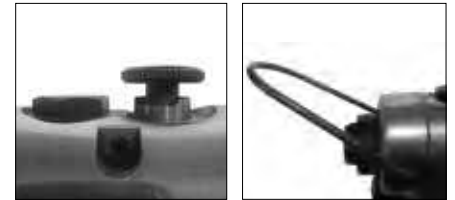
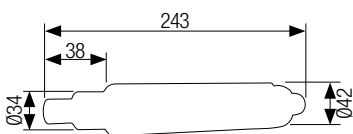

"	mm	Nm		bar	mm	l/sec.	kg	dB(A)	dB(A)	m/sec ²
1/4" E	5	5-6	1.800	6,2	1/4" NPT	10	6,5	85±3	98±3	<2,5

MOD. 620

Cod. 12302080

€ 270,00

Cacciavite reversibile a pistola. Avviamento a pulsante. Scarico posteriore. Frizione regolabile esterna per una maggiore versatilità.

Reversible screwdriver with pistol grip. Start button. Rear exhaust. External adjustable clutch for greater versatility.

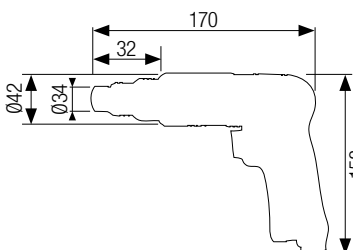

"	mm	Nm		bar	mm	l/sec.	kg	dB(A)	dB(A)	m/sec ²
1/4" E	5	5-7	1.800	6,2	1/4" BSPT	10	1,40	84,3±3	89,7±3	<2,5

REVERSIBLE SCREWDRIVERS

MOD. 605

Cod. 12302005

€ 250,00

Cacciavite reversibile con impugnatura a pistola. Corpo in composito. Avviamento a pulsante. Scarico posteriore. **Frizione positiva.**

Reversible screwdriver with pistol grip. Composite motor housing. Start button. Rear exhaust. **Positive clutch.**



"	mm	Nm		bar	mm	l/sec.	kg	dB(A)	dB(A)	m/sec ²	
1/4"E	7	16	800	6,2	1/4" BSPT	10	2,0	1,10	84±3	95±3	<2,5

MOD. 608

Cod. 12302018

€ 230,00

Cacciavite reversibile con impugnatura a pistola. Corpo in composito. Avviamento a pulsante. Scarico posteriore. Regolazione di serraggio interna.

Reversible screwdriver with pistol grip. Composite motor housing. Start button. Rear exhaust. Internal adjustable clutch.



"	mm	Nm		bar	mm	l/sec.	kg	dB(A)	dB(A)	m/sec ²	
1/4"E	5	3-8	1.800	6,2	1/4" BSPT	10	2,0	1,10	87±3	95±3	<2,5

MOD. 609

Cod. 12302019

€ 260,00

Cacciavite reversibile con impugnatura a pistola. Corpo in composito. Avviamento a pulsante. Scarico posteriore. Regolazione di serraggio interna.

Reversible screwdriver with pistol grip. Composite motor housing. Start button. Rear exhaust. Internal adjustable clutch.



"	mm	Nm		bar	mm	l/sec.	kg	dB(A)	dB(A)	m/sec ²	
1/4"E	6	3-11	800	6,2	1/4" BSPT	10	2,0	1,20	87±3	95±3	<2,5



A person wearing safety glasses is working on a machine. The image is overlaid with a blue digital grid pattern that flows across the frame. The text 'TRAPANI' is prominently displayed in the center-right area.

TRAPANI

Drills

MOD. 375

Cod. 15011001

€ 180,00

Trapano di dimensioni compatte con mandrino autoserrante in composito capacità 6,3 mm. Scarico posteriore.

Compact drill with 6,3 mm self tightening composite chuck. Rear exhaust.

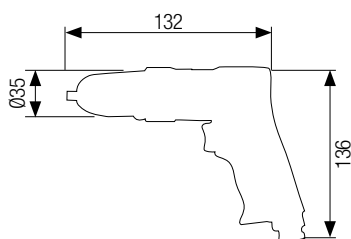

KW											
kW	mm		bar	mm	l/sec.	kg	dB(A)	dB(A)	m/sec ²		
0,19	6,3	3/8" x 24F	2.800	6,2	1/4" BSPT	10	8,3	0,70	84±3	96±3	<2,5

MOD. 380

Cod. 15010040

€ 220,00

Trapano reversibile in composito, con mandrino autoserrante in composito da 10 mm. Pulsante a doppia azione. Scarico posteriore.

Reversible composite drill, with 10 mm self tightening composite chuck. Double action trigger. Rear exhaust.

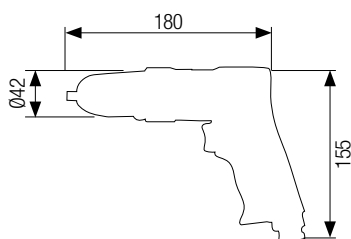
**Mod. AC 100/1**

Cod. 17700151

€ 34,00

Mandrino autoserrante in composito per punte 1 ÷ 10 mm. Attacco 3/8" x 24 F. Self tightening composite chuck (1 ÷ 10 mm. 3/8" x 24 F).

KW											
kW	mm		bar	mm	l/sec.	kg	dB(A)	dB(A)	m/sec ²		
0,33	10	3/8" x 24F	1.800	6,2	1/4" BSPT	10	11,7	1,10	85±3	96±3	<2,5

DRILLS

MOD. 478/A

Cod. 15010010

€ 177,00

Trapano con mandrino autoserrante in composito da 10 mm. Scarico posteriore.

Drill with 10 mm self tightening composite chuck. Rear exhaust.



Mod. AC 100/1

Cod. 17700151

€ 34,00

Mandrino autoserrante in composito per punte 1 ÷ 10 mm. Attacco 3/8" x 24 F. Self tightening composite chuck (1 ÷ 10 mm. 3/8" x 24 F).

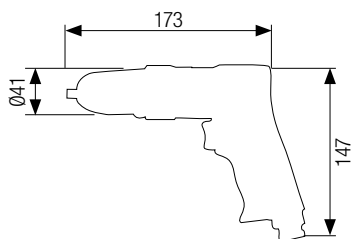

KW											
kW	mm		bar		mm	l/sec.	kg	dB(A)	dB(A)	m/sec ²	
0,35	10	3/8" x 24F	2.500	6,2	1/4" BSPT	10	11,7	1,15	82±3	100±3	<2,5

MOD. 495/A

Cod. 13200040

€ 180,00

Trapano dritto con mandrino autoserrante in composito da 10 mm. Scarico posteriore.

Straight drill with 10 mm self tightening composite chuck. Rear exhaust.



Mod. AC 100/1

Cod. 17700151

€ 34,00

Mandrino autoserrante in composito per punte 1 ÷ 10 mm. Attacco 3/8" x 24 F. Self tightening composite chuck (1 ÷ 10 mm. 3/8" x 24 F).

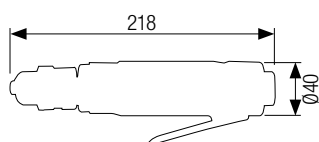

KW											
kW	mm		bar		mm	l/sec.	kg	dB(A)	dB(A)	m/sec ²	
0,35	10	3/8" x 24F	4.000	6,2	1/4" BSPT	10	12,0	0,95	83±3	95±3	<2,5

MOD. 493

Cod. 15010020

€ 170,00

Trapano angolare con mandrino a cremagliera da 10 mm.
Scarico posteriore.

Angle drill with 10 mm key chuck. Rear exhaust.

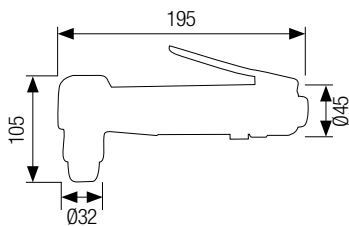

KW											
kW	mm			bar	mm	l/sec.	kg	dB(A)	dB(A)	m/sec ²	
0,30	10	3/8" x 24F	1.600	6,2	1/4" BSPT	10	10,0	1,10	87,4±3	101±3	<2,5

MOD. 496

Cod. 15010021

€ 210,00

Trapano angolare reversibile con mandrino a cremagliera da 10 mm. Scarico posteriore.

Reversible angle drill with 10 mm key chuck. Rear exhaust.

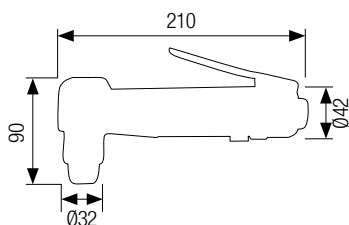

KW											
kW	mm			bar	mm	l/sec.	kg	dB(A)	dB(A)	m/sec ²	
0,25	10	3/8" x 24F	1.900	6,2	1/4" BSPT	10	10,0	1,20	96,7±3	113,7±3	<2,5

DRILLS

MOD. 383

Cod. 15013020

€ 300,00

Trapano reversibile in composito, con mandrino autoserrante in metallo da 13 mm. Pulsante a doppia azione. Scarico posteriore. Impugnatura laterale regolabile.

Reversible composite drill, with 13 mm self tightening metal chuck. Double action trigger. Rear exhaust. Adjustable side handle.

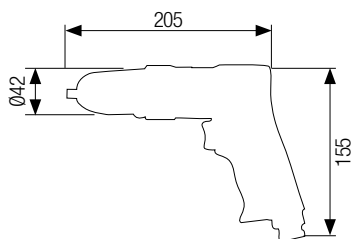

Mod. AC 82/1

Cod. 17700141

€ 70,00

Mandrino auto serrante in metallo per punta 1,5 ÷ 13 mm. Attacco 1/2" x 20 F. Self tightening metal chuck (1,5 ÷ 13 mm. 1/2" x 20 F).



KW											
kW	mm		bar	mm	l/sec.	kg	dB(A)	dB(A)	m/sec ²		
0,33	13	1/2" x 20F	800	6,2	1/4" BSPT	10	11,7	1,30	86±3	93±3	<2,5

MOD. 492/A

Cod. 15013010

€ 260,00

Trapano con mandrino autoserrante in metallo da 13 mm. Scarico posteriore. Impugnatura laterale regolabile.

Drill with 13 mm self tightening metal chuck. Rear exhaust. Adjustable side handle.

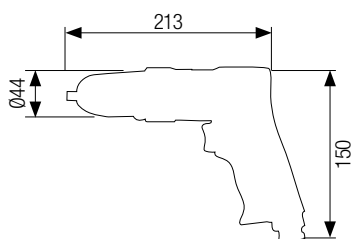

Mod. AC 82/1

Cod. 17700141

€ 70,00

Mandrino auto serrante in metallo per punta 1,5 ÷ 13 mm. Attacco 1/2" x 20 F. Self tightening metal chuck (1,5 ÷ 13 mm. 1/2" x 20 F).



KW											
kW	mm		bar	mm	l/sec.	kg	dB(A)	dB(A)	m/sec ²		
0,38	13	1/2" x 20F	500	6,2	1/4" BSPT	10	10,8	1,90	84±3	97±3	<2,5



MADE IN ITALY



MASCHIATRICI

Air tappers



AIRTEC
TOOLS

CE 8017

AIRTEC
MA
MOD:
Press

WORKING
33
AIRTEC
GRIP

MOD. 590

Cod. 15020000

€ 1.350,00



Maschiatrice a pistola per diametri fino a 8 mm, con mandrino a cambio rapido e dispositivo d'inversione automatica di rotazione. Maschiatrice adatta solo per fori passanti, non adatta per fori ciechi. Impugnatura ausiliaria ed anello di sospensione in dotazione. Maschio e bussola portamaschio non in dotazione.

Pistol type air tapper for diameters up to 8 mm, with quick-change chuck and mechanical automatic rotating inversion device. Air tapper only suitable for through holes, not suitable for dead holes. Supplied with auxiliary handle and suspension hook. Tap and tap holder not included.

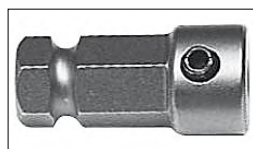

Bussola portamaschio con grano di bloccaggio (esagono 12 mm).

Tap holder with locking dowel (hex 12 mm).

mod.	Cod.	mm*	mm	€
AC 590/1	10705001	2,9	2,2	20,00
AC 590/2	10705002	3,1	2,5	20,00
AC 590/3	10705003	3,6	2,8	20,00
AC 590/4	10705004	4,1	3,1	20,00
AC 590/5	10705005	4,6	3,5	20,00
AC 590/6	10705006	5,1	3,9	20,00
AC 590/7	10705007	6,1	5,0	20,00
AC 590/8	10705008	6,3	5,0	20,00
AC 590/9	10705009	6,6	5,0	20,00
AC 590/10	10705010	7,1	5,6	20,00
AC 590/11	10705011	7,3	5,6	20,00
AC 590/12	10705012	8,1	6,3	20,00

*Gambo maschio Male shank

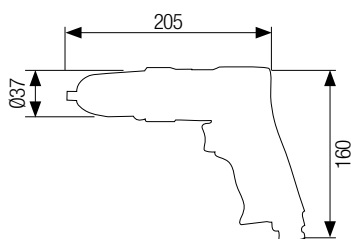

KW										
kW	mm	F	R	bar	mm	l/sec.	kg	dB(A)	m/sec ²	
0,26	8	500	800	6,2	1/4" GAS	8	9,0	1,00	78±3	<2,5

AIR TAPPERS

MOD. 591

Cod. 15020010

€ 1.450,00



Maschiatrice a pistola per diametri fino a 12 mm, con mandrino a cambio rapido e dispositivo d'inversione automatica di rotazione. Maschiatrice adatta solo per fori passanti, non adatta per fori ciechi. Impugnatura ausiliaria ed anello di sospensione in dotazione. Maschio e bussola portamaschio non in dotazione.

Pistol type air tapper for diameters up to 12 mm, with quick-change chuck and mechanical automatic rotating inversion device. Air tapper only suitable for through holes, not suitable for dead holes. Supplied with auxiliary handle and suspension hook. Tap and tap holder not included.

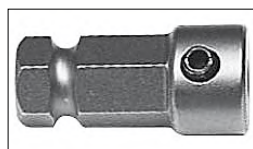

Bussola portamaschio con grano di bloccaggio (esagono 12 mm).
Tap holder with locking dowel (hex 12 mm).

mod.	Cod.	mm*	mm	€
AC 590/1	10705001	2,9	2,2	20,00
AC 590/2	10705002	3,1	2,5	20,00
AC 590/3	10705003	3,6	2,8	20,00
AC 590/4	10705004	4,1	3,1	20,00
AC 590/5	10705005	4,6	3,5	20,00
AC 590/6	10705006	5,1	3,9	20,00
AC 590/7	10705007	6,1	5,0	20,00
AC 590/8	10705008	6,3	5,0	20,00
AC 590/9	10705009	6,6	5,0	20,00
AC 590/10	10705010	7,1	5,6	20,00
AC 590/11	10705011	7,3	5,6	20,00
AC 590/12	10705012	8,1	6,3	20,00
AC 590/13	10705013	8,6	7,1	21,00
AC 590/14	10705014	9,1	7,1	21,00
AC 590/15	10705015	9,5	7,1	21,00
AC 590/16	10705016	10,1	8,1	21,00
AC 590/17	10705017	10,6	8,1	21,00
AC 590/18	10705018	11,1	9,1	21,00
AC 590/19	10705019	12,1	9,1	21,00

*Gambo maschio Male shank

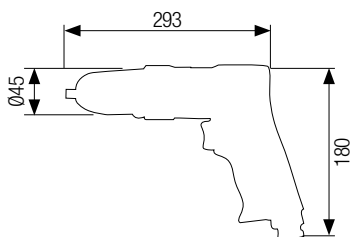

KW										
kW	mm	F	R	bar	1/4" GAS	mm	l/sec.	kg	dB(A)	m/sec ²
0,40	12	220	470	6,2	1/4" GAS	8	11,0	2,08	78±3	<2,5

A dark, atmospheric background featuring a shower of sparks and glowing blue bokeh lights. The sparks are bright orange and yellow, falling from the top right towards the bottom left. The bokeh lights are various shades of blue and cyan, scattered throughout the scene. The overall effect is one of industrial energy and precision.

SMERIGLIATRICI

Grinders



MOD. 250

Cod. 13200050

€ 128,00

Mini smerigliatrice con pinza Ø 3-6 mm. Regolatore dell'aria sul corpo, attacco aria girevole e scarico posteriore. Rivestimento ergonomico in gomma.

Ø 3-6 mm collet mini die grinder. Air regulator on top, swivel air inlet and rear exhaust. Ergonomic ABS sleeve.



Mod. AC 8
Cod. 10700800
€ 26,00

Tubo silenziatore per mod. 250/252/255.

Silenced exhaust hose assembly for mod. 250/252/255.



KW										
kW	mm	bar	mm	l/sec.	kg	dB(A)	dB(A)	m/sec ²		
0,22	3-6	25.000	6,2	1/4" BSPT	10	8,8	0,57	83±3	87±3	<2,5

MOD. 252

Cod. 13200052

€ 188,00

Mini smerigliatrice angolare a 90° con pinza Ø 3-6 mm. Regolatore dell'aria sul corpo, attacco aria girevole e scarico posteriore. Rivestimento ergonomico in gomma.

Ø 3-6 mm collet 90° angle mini die grinder. Air regulator on top, swivel air inlet and rear exhaust. Ergonomic ABS sleeve.



Mod. AC 8
Cod. 10700800
€ 26,00

Tubo silenziatore per mod. 250/252/255.

Silenced exhaust hose assembly for mod. 250/252/255.

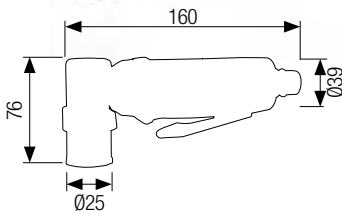

KW										
kW	mm	bar	mm	l/sec.	kg	dB(A)	dB(A)	m/sec ²		
0,22	3-6	20.000	6,2	1/4" BSPT	10	8,8	0,60	83±3	87±3	<2,5

MOD. 255

Cod. 13200055

€ 182,00

Smerigliatrice prolungata con pinza Ø 3-6 mm. Regolatore dell'aria sul corpo, attacco aria girevole e scarico posteriore. Rivestimento ergonomico in gomma.

Ø 3-6 mm collet extended die grinder. Air regulator on top, swivel air inlet and rear exhaust. Ergonomic ABS sleeve.



Mod. AC 8
Cod. 10700800
€ 26,00

Tubo silenziatore per mod. 250/252/255.

Silenced exhaust hose assembly for mod. 250/252/255.

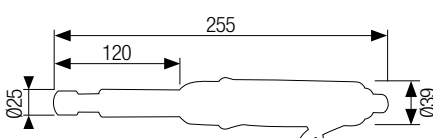

KW										
kW	mm	bar	mm	l/sec.	kg	dB(A)	dB(A)	m/sec ²		
0,22	3-6	25.000	6,2	1/4" BSPT	10	8,8	0,86	83±3	87±3	<2,5

GRINDERS

MOD. 270

Cod. 13200070

€ 168,00

NEW



Smerigliatrice dritta di buona potenza (**0,55 HP**) con pinza \varnothing 6 mm. Smerigliatrice dotata di **sistema di blocco dell'alberino per il cambio degli accessori**, schiacciando e ruotando la calotta anteriore. Regolatore dell'aria sul corpo, attacco aria girevole e scarico posteriore. Possibilità su richiesta di pinza da 3 mm (cod. 4040512243).

\varnothing 6 mm collet die grinder of good power (**0,55 HP**), designed with an easily **spindle lock to change the accessories**; just pushing and rotating the front cap to lock. Equipped with air regulator, swivel air inlet and rear exhaust. 3 mm collet available on demand (cod. 4040512243).



KW										
kW	mm	bar	mm	l/sec.	kg	dB(A)	dB(A)	m/sec ²		
0,41	6	22.000	6,2	1/4" BSPT	10	9,3	0,70	87,5±3	98,5±3	2,7

MOD. 272

Cod. 13200072

€ 254,00

NEW



Smerigliatrice angolare a 90° di buona potenza (**0,55 HP**) con pinza \varnothing 6 mm. Smerigliatrice dotata di **pulsante per il blocco dell'alberino per il cambio degli accessori**. Regolatore dell'aria sul corpo, attacco aria girevole e scarico posteriore. Possibilità su richiesta di pinza da 3 mm (cod. 4040512243).

\varnothing 6 mm collet 90° angle die grinder of good power (**0,55 HP**). Grinder designed with an easily **spindle lock to change the accessories**. Equipped with air regulator, swivel air inlet and rear exhaust. 3 mm collet available on demand (cod. 4040512243).

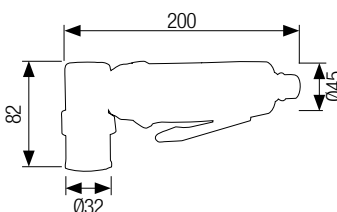

KW										
kW	mm	bar	mm	l/sec.	kg	dB(A)	dB(A)	m/sec ²		
0,41	6	20.000	6,2	1/4" BSPT	10	9,3	0,90	86±3	97±3	2,7

MOD. 275

Cod. 13200075

€ 246,00

NEW



Smerigliatrice prolungata di buona potenza (**0,55 HP**) con pinza \varnothing 6 mm. Smerigliatrice dotata di **sistema di blocco dell'alberino per il cambio degli accessori**, schiacciando e ruotando la calotta anteriore. Regolatore dell'aria sul corpo, attacco aria girevole e scarico posteriore. Possibilità su richiesta di pinza da 3 mm (cod. 4040512243).

\varnothing 6 mm collet extended die grinder of good power (**0,55 HP**), designed with an easily **spindle lock to change the accessories**; just pushing and rotating the front cap to lock. Equipped with air regulator, swivel air inlet and rear exhaust. 3 mm collet available on demand (cod. 4040512243).

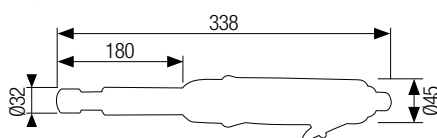

KW										
kW	mm	bar	mm	l/sec.	kg	dB(A)	dB(A)	m/sec ²		
0,41	6	22.000	6,2	1/4" BSPT	10	9,3	1,20	87,5±3	98,5±3	2,7

MOD. 260

Cod. 13200060

€ 210,00

Smerigliatrice dritta 1 HP, per lavori professionali continuativi. Con pinze da 3 e 6 mm, regolatore dell'aria, scarico posteriore e attacco aria girevole. Possibilità su richiesta di pinza da 8 mm (cod. 4052600228).

1 HP die grinder for a continuous professional work. Equipped with 3 and 6 mm collets, air regulator, rear exhaust and swivel air inlet. 8 mm collet available on demand (cod. 4052600228).

1HP = 0,75 KW



KW										
kW	mm		bar	mm	mm	l/sec.	kg	dB(A)	dB(A)	m/sec ²
0,75	3-6	20.000	6,2	1/4" BSPT	10	14	0,80	82±3	93±3	3,0

MOD. 262

Cod. 13200062

€ 320,00

Smerigliatrice angolare 90° 1 HP, per lavori professionali continuativi. Con pinze da 3 e 6 mm, regolatore dell'aria, scarico posteriore e attacco aria girevole. Possibilità su richiesta di pinza da 8 mm (cod. 4052600228).

1 HP 90° angle grinder for a continuous professional work. Equipped with 3 and 6 mm collets, air regulator, rear exhaust and swivel air inlet. 8 mm collet available on demand (cod. 4052600228).

1HP = 0,75 KW

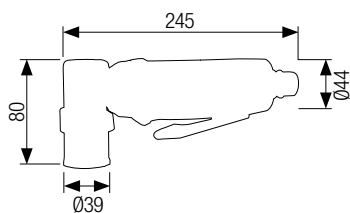

KW										
kW	mm		bar	mm	mm	l/sec.	kg	dB(A)	dB(A)	m/sec ²
0,75	3-6	12.000	6,2	1/4" BSPT	10	14	1,04	84±3	95±3	3,0

MOD. 265

Cod. 13200065

€ 310,00

Smerigliatrice prolungata 1 HP, per lavori professionali continuativi. Con pinze da 3 e 6 mm, regolatore dell'aria, scarico posteriore e attacco aria girevole. Possibilità su richiesta di pinza da 8 mm (cod. 4052600228).

1 HP extended grinder for a continuous professional work. Equipped with 3 and 6 mm collets, air regulator, rear exhaust and swivel air inlet. 8 mm collet available on demand (cod. 4052600228).

1HP = 0,75 KW

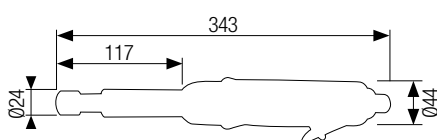

KW										
kW	mm		bar	mm	mm	l/sec.	kg	dB(A)	dB(A)	m/sec ²
0,75	3-6	18.000	6,2	1/4" BSPT	10	14	0,98	83±3	94±3	2,9

GRINDERS

MOD. 484

Cod. 13200000

€ 112,00

Smerigliatrice fresatrice con pinza Ø 6 mm e adattatore per frese Ø 3 mm. Regolatore dell'aria e scarico posteriore. Rivestimento ergonomico in gomma.

Ø 6 mm collet die grinder, equipped with Ø 3 mm adapter. Air regulator and rear exhaust. Ergonomic ABS sleeve.

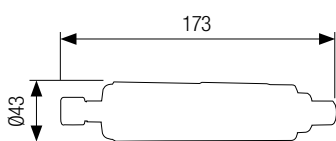

KW										
kW	mm	bar		mm	l/sec.	kg	dB(A)	dB(A)	m/sec ²	
0,20	3-6	20.000	6,2	1/4" BSPT	10	12,5	0,62	92,3±3	95,3±3	<2,5

MOD. 485

Cod. 13200005

€ 150,00

Smerigliatrice a bassa velocità, con filetto 5/16" adatta per la rimozione di adesivi o per lavori di levigatura, sgrassatura e pulizia di superfici. Regolatore dell'aria e scarico posteriore.

Low speed eraser with 5/16" thread, suitable for removing adhesive tapes and smoothing, roughing and cleaning surfaces. Air regulator and rear exhaust.

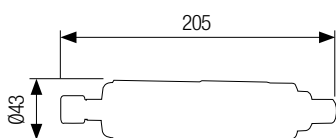

Mod. AC 18

Cod. 10702010

€ 10,00

Disco in gomma Ø 88 mm.
Ø 88 mm rubber wheel.

mm	bar		mm	l/sec.	kg	dB(A)	m/sec ²	
90	2.600	6,2	1/4" BSPT	10	11,6	0,84	84±3	<2,5

MOD. 495/F

Cod. 13200045

€ 165,00

Smerigliatrice fresatrice con pinza Ø 6 mm. Regolatore dell'aria e scarico posteriore. Possibilità su richiesta di pinza da 8 mm (cod. 4052600228).

Ø 6 mm collet die grinder. Air regulator and rear exhaust. 8 mm collet available on demand (cod. 4052600228).



Mod. AC 18

Cod. 10702010

€ 10,00

Disco in gomma Ø 88 mm.
Ø 88 mm rubber wheel.

Cod. 10702011 € 2,80

Perno adattatore 9 mm per AC 18.
9 mm adaptor for AC 18.

Cod. 10702012 € 2,80

Perno adattatore 6 mm per AC 18.
6 mm adaptor for AC 18.

KW										
kW	mm	bar		mm	l/sec.	kg	dB(A)	dB(A)	m/sec ²	
0,30	6	4.000	6,2	1/4" BSPT	10	12,0	0,85	83±3	95±3	<2,5

MOD. 489

Cod. 13200020

€ 155,00

Smerigliatrice prolungata con pinza Ø 6 mm. Regolatore dell'aria e scarico posteriore. Rivestimento ergonomico in gomma.

Ø 6 mm collet extended grinder. Air regulator and rear exhaust. Ergonomic ABS sleeve.

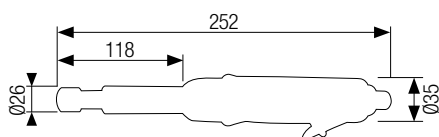

kW	mm		bar		mm	l/sec.	kg	dB(A)	dB(A)	m/sec ²
0,30	6	20.000	6,2	1/4" BSPT	10	8,0	0,65	91±3	101±3	<2,5

MOD. 487

Cod. 13200012

€ 178,00

Mini smerigliatrice angolare silenziosa, fornita con plettorello Ø 50 mm e un disco abrasivo grana 80. Attacco tipo 3M Roloc e filetto maschio 1/4" x 20F. Utensile con scarico posteriore e tubo per convogliare rumore e scarico lontano dall'operatore.

Silenced mini angle grinder, equipped with Ø 50 mm pad and one 80 grit grinding wheel. 3M Roloc connection and 1/4" x 20F male thread. Tool with rear exhaust and hose to convey the noise away from the user.

**Mod. AC 70**

Cod. 10700600 € 9,00

Plattorello Ø 50 mm
Ø 50 mm rubber pad

**Mod. AC 71**

Cod. 10700610 € 10,00

Plattorello Ø 70 mm
Ø 70 mm rubber pad

**Mod. AC 72-73-74**

Cod. 10700620-1-2 € 22,00

Spazzola 3M roloc Ø 50 mm
Ø 50 mm 3M roloc brush

Grana: 50 verde - 80 giallo - 120 bianco.
Grit: 50 green - 80 yellow - 120 white.



mm		bar		mm	l/sec.	kg	dB(A)	m/sec ²
50/70	25.000	6,2	1/4" BSPT	8	5,0	0,65	82±3	<2,5

GRINDERS

MOD. 700

Cod. 13200500

€ 240,00

Smerigliatrice veloce a 54.000 giri, con pinza Ø 3 mm e Ø 2,35 mm. Ghiera regolatore per ingresso aria progressivo. Utensile con scarico posteriore e tubo per convogliare rumore e scarico lontano dal posto di lavoro. In dotazione mini oliatore, contenitore olio e chiavi.

High speed 54.000 rpm grinder, with Ø 3 mm and Ø 2,35 mm collets. Regulating ring nut for progressive air inlet. Tool with rear exhaust and hose to convey the noise away from the workplace. Equipped with mini oiler, oil pot and key wrenches.

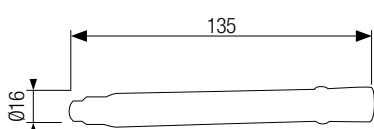

KW									
kW	mm		bar	1/4" NPT	mm	l/sec.	kg	dB(A)	m/sec ²
0,19	3	54.000	6,2	1/4" NPT	8	5,0	0,20	84±3	5,0

MOD. 710

Cod. 13200510

€ 290,00

Smerigliatrice veloce a 70.000 giri, con pinza Ø 3 mm e Ø 2,35 mm. Ghiera regolatore per ingresso aria progressivo. Utensile con scarico posteriore e tubo per convogliare rumore e scarico lontano dal posto di lavoro. In dotazione mini oliatore, contenitore olio e chiavi.

High speed 70.000 rpm grinder, with Ø 3 mm and Ø 2,35 mm collets. Regulating ring nut for progressive air inlet. Tool with rear exhaust and hose to convey the noise away from the workplace. Equipped with mini oiler, oil pot and key wrenches.

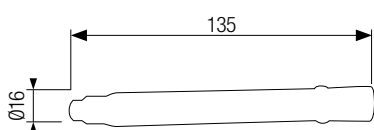

KW									
kW	mm		bar	1/4" NPT	mm	l/sec.	kg	dB(A)	m/sec ²
0,19	3	70.000	6,2	1/4" NPT	8	5,0	0,20	80±3	4,0

MOD. 715

Cod. 13200515

€ 240,00

Smerigliatrice veloce angolare con filetto M7*0,75. In dotazione platorello ø 30 mm per accessori autoadesivi, 5 mole (grane #60 - 320 - 400 - 600 - 1500) e 6 dischi abrasivi grana #60. Utensile con scarico posteriore e tubo per convogliare rumore e scarico lontano dal posto di lavoro.

High speed angle grinder with M7*0,75 thread. Equipped with ø 30 mm self-stick pad, 5 grinding wheels (grit #60 - 320 - 400 - 600 - 1500) and 6 sanding pads grit 60. Tool with rear exhaust and hose to convey the noise away from the workplace.

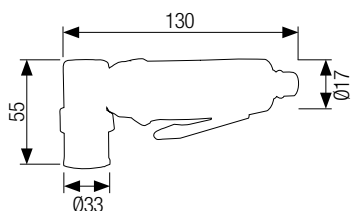

	KW									
mm	kW		bar	1/4" BSPT	mm	l/sec.	kg	dB(A)	dB(A)	m/sec ²
30	0,30	23.000	6,2	1/4" BSPT	8	5,0	0,15	82,8±3	93,8±3	2,4

MOD. 416

Cod. 13009700

€ 420,00

Smerigliatrice angolare leggera di buona potenza, per lavori gravosi. Con disco Ø 125 mm, leva di sicurezza e albero filettato M14. Scarico posteriore. Il carter di protezione della mola può essere orientato radialmente in tutte le posizioni. **Macchina dotata di fermo di sicurezza del disco.** I dischi abrasivi devono essere scelti in funzione del lavoro da eseguire, possono essere sia piatti, sia a centro depresso, e devono rispettare le seguenti caratteristiche: Diametro interno: 22,2 mm - Diametro esterno: 125 mm o inferiore - Spessore: da 1 a 7 mm - Adeguata velocità di rotazione: 12.000 giri/min (78,5 m/sec) o superiore.

Heavy-duty light angle grinder. Ø 125 mm disc, safety lever and M14 thread spindle. Rear exhaust. The protecting case of the wheel can be oriented radially in all positions. **Tool equipped with a disc safety stop device.** The abrasive disks must be chosen depending on the work to be performed, they can be either flat or depressed center and must meet the following characteristics: Internal diameter: 22,2 mm - External diameter: 125 mm or less - Thickness: 1 to 7 mm - Adequate rotation speed: 12.000 rpm (78,5 m/sec) or greater.

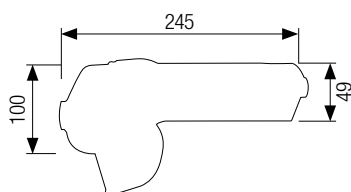

KW	mm	mm	bar	mm	l/sec.	kg	dB(A)	dB(A)	m/sec ²	
0,65	125x22	10.000	6,2	1/4" NPT	10	11,7	1,80	84±3	96±3	2,9

MOD. 417

Cod. 13009800

€ 340,00

Smerigliatrice angolare leggera e maneggevole Ø 125 mm, gambo M14. Capacità abrasiva Ø 125 mm. Il carter di protezione della mola può essere orientato in 8 diverse posizioni. I dischi abrasivi devono essere scelti in funzione del lavoro da eseguire, possono essere sia piatti, sia a centro depresso, e devono rispettare le seguenti caratteristiche: Diametro interno: 22,2 mm - Diametro esterno: 125 mm o inferiore - Spessore: da 2,5 a 7 mm - Adeguata velocità di rotazione: 12.000 giri/min (78,5 m/sec) o superiore.

Light and handy Ø 125 mm angle grinder, with M14 thread. The protecting case of the wheel can be adjusted in 8 different positions. The abrasive disks must be chosen depending on the work to be performed, they can be either flat or depressed center and must meet the following characteristics: Internal diameter: 22,2 mm - External diameter: 125 mm or less - Thickness: 2,5 to 7 mm - Adequate rotation speed: 12.000 rpm (78,5 m/sec) or greater.

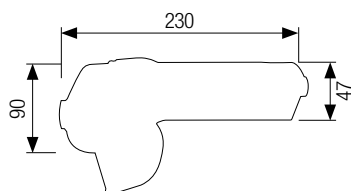

KW	mm	mm	bar	mm	l/sec.	kg	dB(A)	dB(A)	m/sec ²	
0,60	125x22	12.000	6,2	1/4" BSPT	10	11,8	1,80	86±3	94±3	<2,5

GRINDERS

MOD. 435









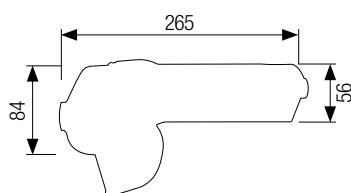

Cod. 13114500

€ 400,00

Smerigliatrice angolare Ø 125 mm per uso professionale, gambo M14. Il carter di protezione della mola può essere orientato radialmente in tutte le posizioni. Maniglia laterale antivibrante in dotazione. I dischi abrasivi devono essere scelti in funzione del lavoro da eseguire, possono essere sia piatti, sia a centro depresso, e devono rispettare le seguenti caratteristiche: Diametro interno: 22,2 mm - Diametro esterno: 125 mm o inferiore - Spessore: da 1 a 7 mm - Adeguata velocità di rotazione: 10.900 giri/min (71,3 m/sec) o superiore.

Ø 125 mm angle grinder for professional use, with M14 spindle thread. The protecting case of the wheel can be oriented radially in all positions. Supplied with anti-vibration side handle. The abrasive disks must be chosen depending on the work to be performed, they can be either flat or depressed center and must meet the following characteristics: Internal diameter: 22,2 mm - External diameter: 125 mm or less - Thickness: 1 to 7 mm - Adequate rotation speed: 10.900 rpm (71,3 m/sec) or greater.



										
kW	mm	bar	mm	l/sec.	kg	dB(A)	dB(A)	m/sec ²		
0,75	125x22	10.900	6,2	1/4" BSPT	10	17,5	1,90	78±3	90±3	<2,5

MOD. 520









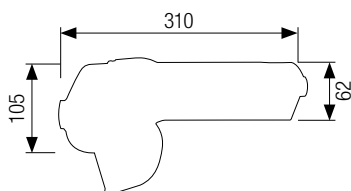

Cod. 13018020

€ 585,00

Smerigliatrice angolare Ø 180 mm per uso professionale, gambo M14. Il carter di protezione della mola può essere orientato radialmente in tutte le posizioni. Maniglia laterale antivibrante in dotazione. **Macchina dotata di fermo di sicurezza del disco.** I dischi abrasivi devono essere scelti in funzione del lavoro da eseguire, devono essere a centro depresso e rispettare le seguenti caratteristiche: Diametro esterno: 180 mm o inferiore - Adeguata velocità di rotazione: 7.600 giri/min o superiore.

Ø 180 mm angle grinder for professional use, with M14 spindle thread. The protecting case of the wheel can be oriented radially in all positions. Supplied with anti-vibration side handle. **Tool equipped with a disc safety stop device.** The abrasive disks must be chosen depending on the work to be performed, they must be depressed center and meet the following characteristics: External diameter: 180 mm or less - Adequate rotation speed: 7.600 rpm or greater.



										
kW	mm	bar	mm	l/sec.	kg	dB(A)	dB(A)	m/sec ²		
0,75	180	7.600	6,2	3/8" BSPT	16	24,0	3,00	89,2±3	100,3±3	4,0

MOD. 525

Cod. 13019000

€ 800,00

Smerigliatrice angolare Ø 230 mm per uso professionale, con filetto 5/8" – 11. Il carter di protezione della mola può essere orientato radialmente in tutte le posizioni. Maniglia laterale antivibrante in dotazione. **Macchina dotata di fermo di sicurezza del disco.** I dischi abrasivi devono essere scelti in funzione del lavoro da eseguire, devono essere a centro depresso e rispettare le seguenti caratteristiche: Diametro esterno: 230 mm o inferiore - Adeguata velocità di rotazione: 5.900 giri/min o superiore.

Ø 230 mm angle grinder for professional use, with 5/8" – 11 thread. The protecting case of the wheel can be oriented radially in all positions. Supplied with anti-vibration side handle. **Tool equipped with a disc safety stop device.** The abrasive disks must be chosen depending on the work to be performed, they must be depressed center and meet the following characteristics: External diameter: 230 mm or less – Adequate rotation speed: 5.900 rpm or greater.

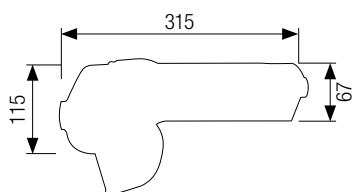

KW	mm	mm	bar	mm	mm	l/sec.	kg	dB(A)	dB(A)	m/sec ²
1,86	230	5.900	6,2	3/8" BSPT	16	19,6	3,30	93,2±3	104,2±3	2,73

MOD. 415

Cod. 13009000

€ 670,00

Smerigliatrice verticale Ø 230 mm per utilizzo professionale, con filetto 5/8" – 11. I dischi abrasivi devono essere scelti in funzione del lavoro da eseguire, devono essere a centro depresso e rispettare le seguenti caratteristiche: Diametro interno: 22,2 mm - Diametro esterno: 230 mm o inferiore - Spessore: da 1 a 8 mm – Adeguata velocità di rotazione: 6.000 giri/min (72,2 m/sec) o superiore.

Ø 230 mm professional vertical die grinder, with 5/8" – 11 thread. The abrasive disks must be chosen depending on the work to be performed, they must be depressed center and meet the following characteristics: Internal diameter: 22,2 mm – External diameter: 230 mm or less - Thickness: 1 to 8 mm – Adequate rotation speed: 6.000 rpm (72,2 m/sec) or greater.

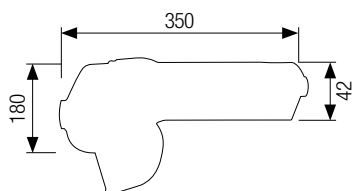

KW	mm	mm	bar	mm	mm	l/sec.	kg	dB(A)	dB(A)	m/sec ²
2,22	230x22	6.000	6,2	1/2" BSPT	16	26,0	5,10	95±3	103±3	4,1

GRINDERS

MOD. 423

Cod. 13118000

€ 260,00

Smerigliatrice a nastro, per nastri 10 x 330 mm. Blocco del braccio nella posizione desiderata. Scarico posteriore e attacco aria girevole. In dotazione un nastro grana 80 e uno grana 120.

Belt sander for 10 x 330 mm grinding belt. Possibility to hold the arm in the desired position. Rear exhaust and swivel air inlet. Equipped with one 80 grit belt and one 120 grit belt.



Nastro abrasivo 10 x 330 mm 10 x 330 mm grinding belt					Nastro abrasivo ceramico 10 x 330 mm 10 x 330 mm ceramic grinding belt				
Confezione tassativa 10 pz 10 pcs per pack					Confezione tassativa 10 pz 10 pcs per pack				
Mod.	Cod.	Grana	Grit	€	Mod.	Cod.	Grana	Grit	€
AC 19/4	10702215	40		2,50 cad.	AC 119	10712100	40		2,80 cad.
AC 19	10702090	80		2,50 cad.	AC 119/1	10712110	60		2,80 cad.
AC 19/1	10702100	120		2,50 cad.	AC 119/2	10712120	80		2,80 cad.

kW	mm	bar	mm	l/sec.	kg	dB(A)	dB(A)	m/sec ²	
0,37	10x330	18.000	6,2	1/4" BSPT	10	11,2	0,90	86±3 93±3	<2,5

MOD. 424

Cod. 13118100

€ 325,00

Smerigliatrice a nastro, per nastri 20 x 520 mm. Blocco del braccio nella posizione desiderata. Scarico posteriore e attacco aria girevole. In dotazione un nastro grana 80 e uno grana 120.

Belt sander for 20 x 520 mm grinding belt. Possibility to hold the arm in the desired position. Rear exhaust and swivel air inlet. Equipped with one 80 grit belt and one 120 grit belt.



Nastro abrasivo 20 x 520 mm 20 x 520 mm grinding belt					Nastro abrasivo ceramico 20 x 520 mm 20 x 520 mm ceramic grinding belt				
Confezione tassativa 10 pz 10 pcs per pack					Confezione tassativa 10 pz 10 pcs per pack				
Mod.	Cod.	Grana	Grit	€	Mod.	Cod.	Grana	Grit	€
AC 19/5	10702220	40		3,00 cad.	AC 120	10712200	40		3,50 cad.
AC 19/2	10702200	80		3,00 cad.	AC 120/1	10712210	60		3,50 cad.
AC 19/3	10702210	120		3,00 cad.	AC 120/2	10712220	80		3,50 cad.

kW	mm	bar	mm	l/sec.	kg	dB(A)	dB(A)	m/sec ²	
0,52	20x520	16.000	6,2	1/4" BSPT	10	12,0	1,40	84±3 92±3	<2,5

MOD. 425

Cod. 13118200

€ 430,00

Smerigliatrice a nastro, per nastri 30 x 540 mm. Blocco del braccio nella posizione desiderata. Scarico posteriore e attacco aria girevole. In dotazione un nastro grana 80 e uno grana 120.

Belt sander for 30 x 540 mm grinding belt. Possibility to hold the arm in the desired position. Rear exhaust and swivel air inlet. Equipped with one 80 grit belt and one 120 grit belt.



Mod. AC 19/6 Cod. 10702225 € 4,00 cad.	Mod. AC 19/7 Cod. 10702230 € 4,00 cad.								
Nastro abrasivo 30x540 mm – grana 80 30x540 mm grinding belt – grit 80. Confezione tassativa 10 pz 10 pcs per pack	Nastro abrasivo 30x540 mm – grana 120 30x540 mm grinding belt – grit 120. Confezione tassativa 10 pz 10 pcs per pack								
kW	mm	bar	mm	l/sec.	kg	dB(A)	dB(A)	m/sec ²	
0,52	30x540	12.000	6,2	1/4" BSPT	10	13,0	2,30	85±3 96±3	3,1





TRONCATRICI

Cut off tools

MOD. 543

Cod. 16070030

€ 320,00

Smerigliatrice/troncatrice angolare, leggera, di buona potenza. Adatta per dischi \varnothing 100 mm o inferiori e di spessore da 1 a 2 mm. Pulsante di bloccaggio del disco. Il carter di protezione della mola può essere orientato in 11 posizioni a 126° .

Light corner grinder/cut off tool with good power. Suitable for disks with 100 mm or less external diameter and thickness from 1 to 2 mm. Lock disk button. The turnable guard can adjust 11 positions in 126° .



Mod. AC 543
Cod. 10700543
€ 65,00

Set 25 dischi da taglio 100 x 1 x 10 mm.

25 pcs set 100 x 1 x 10 mm cutting wheels.



Mod. AC 50/1
Cod. 10700501
€ 2,00 cad.

Disco da taglio per acciaio \varnothing 75 x 10 mm, spessore 1 mm.

Cutting wheel for steel, \varnothing 75 x 10 mm, 1 mm thickness.

Confezione tassativa 10 pz
10 pcs per pack



Mod. AC 50/2
Cod. 10700502
€ 2,00 cad.

Disco da taglio per acciaio \varnothing 75 x 10 mm, spessore 1,5 mm.

Cutting wheel for steel, \varnothing 75 x 10 mm, 1,5 mm thickness.

Confezione tassativa 10 pz
10 pcs per pack



Mod. AC 545/4
Cod. 4040542007
€ 3,60 cad.

Disco da taglio \varnothing 50 x 10 mm, spessore 1,2 mm.

\varnothing 50 x 10 mm cutting wheel, 1,2 mm thickness.

Confezione tassativa 10 pz
10 pcs per pack

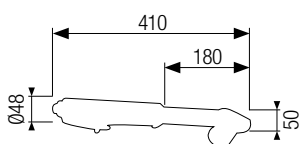
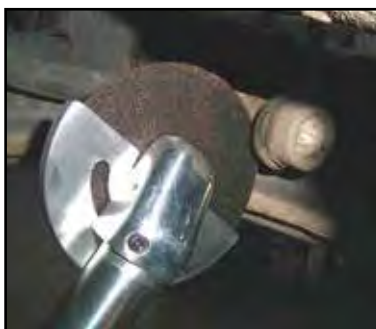

KW										
kW	mm	17.000	bar	1/4" BSPT	mm	l/sec.	kg	dB(A)	dB(A)	m/sec ²
0,75	100	17.000	6,2	1/4" BSPT	10	5,0	1,40	93,3±3	104,3±3	5±1

CUT OFF TOOLS

MOD. 540

Cod. 16070000

€ 110,00

Troncatrice Ø 75 x 10 mm per tagliare marmitte, bulloni, viti, etc. In dotazione un disco da taglio spessore 1,5 mm (mod. AC 50/2).

Ø 75 x 10 mm cut off tool. To cut off mufflers, bolts, screws, etc. Equipped with 1 pc 1,5 mm cutting wheel (mod. AC 50/2).



Mod. AC 50/1
Cod. 10700501

€ 2,00 cad.

Disco da taglio per acciaio Ø 75 x 10 mm, spessore 1 mm.

Cutting wheel for steel, Ø 75 x 10 mm, 1 mm thickness.

Confezione tassativa 10 pz
10 pcs per pack



Mod. AC 545/4
Cod. 4040542007

€ 3,60 cad.

Disco da taglio Ø 50 x 10 mm, spessore 1,2 mm.

Ø 50 x 10 mm cutting wheel, 1,2 mm thickness.

Confezione tassativa 10 pz
10 pcs per pack



Mod. AC 50/2
Cod. 10700502

€ 2,00 cad.

Disco da taglio per acciaio Ø 75 x 10 mm, spessore 1,5 mm.

Cutting wheel for steel, Ø 75 x 10 mm, 1,5 mm thickness.

Confezione tassativa 10 pz
10 pcs per pack

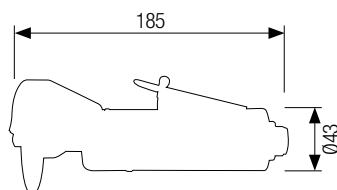

KW	mm	mm	bar	mm	l/sec.	kg	dB(A)	dB(A)	m/sec ²	
0,20	75	22.000	6,2	1/4" BSPT	10	11,7	0,80	92,3±3	95,3±3	<2,5

MOD. 545

Cod. 16070050

€ 230,00

Mini smerigliatrice/troncatrice angolare, disco Ø 50 x 10 mm. Kit comprendente: 5 dischi da taglio, 9 dischi abrasivi (3 x grana 60, 3 x grana 80, 3 x grana 120), occhiali di protezione e 2 chiavi.

Ø 50 x 10 mm mini angle grinder and cut-off tool. The kit includes: 5 cutting wheels, 9 grinding wheels (3 x 60 grit, 3 x 80 grit and 3 x 120 grit), safety glasses and 2 wrenches.



€ 6,00 cad.

Mod. AC 545/1

Cod. 40483A3911

Disco abrasivo 2" grana 60.

2" grinding wheel grit 60.

Confezione tassativa 10 pz
10 pcs per pack



€ 6,00 cad.

Mod. AC 545/2

Cod. 40483A3912

Disco abrasivo 2" grana 80.

2" grinding wheel grit 80.

Confezione tassativa 10 pz
10 pcs per pack



€ 6,00 cad.

Mod. AC 545/3

Cod. 40483A3913

Disco abrasivo 2" grana 120.

2" grinding wheel grit 120.

Confezione tassativa 10 pz
10 pcs per pack



€ 3,60 cad.

Mod. AC 545/4

Cod. 4040542007

Disco da taglio Ø 50 x 10 mm, spessore 1,2 mm.

Ø 50 x 10 mm cutting wheel, 1,2 mm thickness.

Confezione tassativa 10 pz
10 pcs per pack

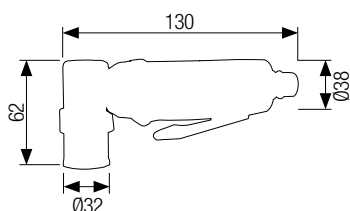

KW	mm	mm	bar	mm	l/sec.	kg	dB(A)	dB(A)	m/sec ²	
0,19	50	20.000	6,2	1/4" BSPT	8	7,5	0,50	83±3	92±3	<2,5



A hand is shown using a circular sanding disc with a red and black border on a white surface. The background features a car wheel and a blue, dotted, curved structure. The overall scene is brightly lit, emphasizing the texture of the sanding disc and the surface being worked on.

LEVIGATRICI E PULITRICI

Sanders and polishers

MOD. 236

Cod. 13112600

€ 220,00

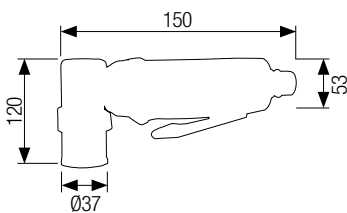

Kit mini pulitrice 3" con corpo in composito. Kit comprendente: piattovelcro ø 75 mm, cuffia di lana 3-1/2", 2 piatti per lucidatura 3-1/2" (bianco e giallo) e una chiave.

3" mini polisher kit with composite body. The kit includes: ø 75 mm velcro sanding pad, 3-1/2" bonnet, 2 pcs 3-1/2" compounding pad (white and yellow) and one key.

Cod.	Confezione tassativa 10 pz 10 pcs per pack	€
10702041	Disco abrasivo 3" - grana 1000 3" sanding paper - grit 1000	2,50 cad.
10702042	Disco abrasivo 3" - grana 2000 3" sanding paper - grit 2000	2,50 cad.



Mod. AC 77

Cod. 10700630 € 16,00

Platovelcro ø 50 mm. Filetto M6 x 1
Ø 50 mm velcro pad. M6 x 1 thread

Mod. AC 78

Cod. 10700631 € 18,00

Platovelcro ø 75 mm. Filetto M6 x 1
Ø 75 mm velcro pad. M6 x 1 thread

Mod.	Cod.		€
AC 236/1	4040600433	Cuffia di lana 3-1/2" 3-1/2" bonnet	17,00
AC 236/2	4040600434	Platovelcro bianco per lucidatura 3-1/2" 3-1/2" white compounding pad	17,00
AC 236/3	4040600435	Platovelcro giallo per lucidatura 3-1/2" 3-1/2" yellow compounding pad	17,00

KW	mm	bar	mm	l/sec.	kg	dB(A)	dB(A)	m/sec ²		
0,26	75	3,200	6,2	1/4" BSPT	10	9,16	0,72	88±3	94±3	<2,5

MOD. 237

Cod. 13112700

€ 200,00

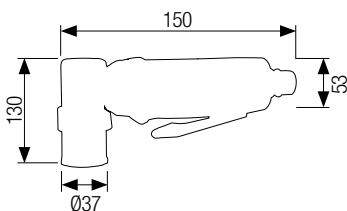

Kit mini levigatrice orbitale 2 & 3" con corpo in composito. Kit comprendente: 2 platoveli ø 75 mm (2 & 3"), 30 carte abrasive 2" (10 x grana 320, 10 x grana 400 e 10 x grana 600), 30 carte abrasive 3" (10 x grana 320, 10 x grana 400 e 10 x grana 600) e una chiave.

2 & 3" mini orbital sander kit with composite body. The kit includes: 2 velcro sanding pads (2 & 3"), 30 pcs 2" sanding papers (10 x grit 320, 10 x grit 400 and 10 x grit 600), 30 pcs 3" sanding papers (10 x grit 320, 10 x grit 400 and 10 x grit 600) and one key.

Cod.	Confezione tassativa 10 pz 10 pcs per pack	€
10702041	Disco abrasivo 3" - grana 1000 3" sanding paper - grit 1000	2,50 cad.
10702042	Disco abrasivo 3" - grana 2000 3" sanding paper - grit 2000	2,50 cad.



Mod. AC 77

Cod. 10700630

€ 16,00

Platovelcro ø 50 mm. Filetto M6 x 1
Ø 50 mm velcro pad. M6 x 1 thread

Mod. AC 78

Cod. 10700631

€ 18,00

Platovelcro ø 75 mm. Filetto M6 x 1
Ø 75 mm velcro pad. M6 x 1 thread

Mod.	Cod.	Confezione tassativa 10 pz 10 pcs per pack	€
AC 237/21	4046003V24	Disco abrasivo 2" - grana 320 2" sanding paper - grit 320	1,50 cad.
AC 237/22	4046003V25	Disco abrasivo 2" - grana 400 2" sanding paper - grit 400	1,50 cad.
AC 237/23	4046003V26	Disco abrasivo 2" - grana 600 2" sanding paper - grit 600	1,50 cad.
AC 237/31	4046003V34	Disco abrasivo 3" - grana 320 3" sanding paper - grit 320	2,00 cad.
AC 237/32	4046003V35	Disco abrasivo 3" - grana 400 3" sanding paper - grit 400	2,00 cad.
AC 237/33	4046003V36	Disco abrasivo 3" - grana 600 3" sanding paper - grit 600	2,00 cad.

mm	KW	mm	bar	mm	l/sec.	kg	dB(A)	dB(A)	m/sec ²		
4	0,26	75	15.000	6,2	1/4" BSPT	10	9,16	0,64	87±3	94±3	<2,5

SANDERS AND POLISHERS

MOD. 530

Cod. 13115100

€ 224,00

Mini levigatrice palmare rotorbitale, senza aspirazione. Platorello velcro ø 75 mm. Corpo in composito, molto leggero ed ergonomico.

Random orbital palm sander, ø 75 mm velcro pad. Very light and ergonomic composite body.

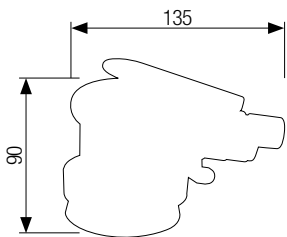

Mod.	Cod.	Confezione tassativa 10 pz - 10 pcs per pack		€
AC 237/31	4046003V34	Disco abrasivo 3" - grana 320	3" sanding paper - grit 320	2,00 cad.
AC 237/32	4046003V35	Disco abrasivo 3" - grana 400	3" sanding paper - grit 400	2,00 cad.
AC 237/33	4046003V36	Disco abrasivo 3" - grana 600	3" sanding paper - grit 600	2,00 cad.

Cod.	Confezione tassativa 10 pz 10 pcs per pack	€
10702041	Disco abrasivo 3" - grana 1000 3" sanding paper - grit 1000	250 cad.
10702042	Disco abrasivo 3" - grana 2000 3" sanding paper - grit 2000	250 cad.



Mod. AC 78/1
Cod. 10700632 € 26,00

Platorello velcro ø 75 mm. Filetto 5/16" x 24F
Ø 75 mm velcro pad. 5/16" x 24F thread

Cod. 1070063201 € 31,00

Platorello originale in velcro ø 75 mm.
Filetto 5/16" x 24F

Original ø 75 mm velcro pad. 5/16" x 24F thread

mm	kW	mm		bar		mm	l/sec.	kg	dB(A)	dB(A)	m/sec ²
2,5	0,19	75	12.000	6,2	1/4" BSPT	8	6,8	0,60	80±3	95±3	5,24

MOD. 750

Cod. 13117000

€ 350,00

NEW

Mini levigatrice palmare rotorbitale, senza aspirazione, per platorelli velcro ø 75 mm. Corpo in composito, molto leggero, estremamente ergonomico, grazie all'apposito **supporto per il polso**. Il motore pneumatico brevettato a doppia tenuta e privo di lubrificazione consente un **utilizzo senza olio**.

Random orbital palm sander, without suction, for ø 75 mm pad. Very light composite body, extremely ergonomic, thanks to the **special wrist support**. Patented double sealed, lubrication-free air motor provides **oil-free use**.



OIL FREE

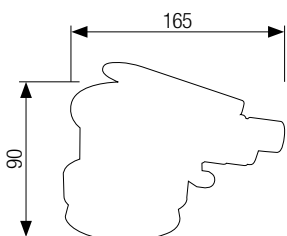

Mod.	Cod.	Confezione tassativa 10 pz - 10 pcs per pack		€
AC 237/31	4046003V34	Disco abrasivo 3" - grana 320	3" sanding paper - grit 320	2,00 cad.
AC 237/32	4046003V35	Disco abrasivo 3" - grana 400	3" sanding paper - grit 400	2,00 cad.
AC 237/33	4046003V36	Disco abrasivo 3" - grana 600	3" sanding paper - grit 600	2,00 cad.

Cod.	Confezione tassativa 10 pz 10 pcs per pack	€
10702041	Disco abrasivo 3" - grana 1000 3" sanding paper - grit 1000	250 cad.
10702042	Disco abrasivo 3" - grana 2000 3" sanding paper - grit 2000	250 cad.



Mod. AC 78/1
Cod. 10700632 € 26,00

Platorello velcro ø 75 mm. Filetto 5/16" x 24F
Ø 75 mm velcro pad. 5/16" x 24F thread

Cod. 1070063201 € 31,00

Platorello originale in velcro ø 75 mm.
Filetto 5/16" x 24F

Original ø 75 mm velcro pad. 5/16" x 24F thread

mm	kW	mm		bar		mm	l/sec.	kg	dB(A)	dB(A)	m/sec ²
2,5	0,22	75	11.000	6,2	1/4" BSPT	10	0,8	0,60	80±3	91±3	0,9

MOD. 532

Cod. 13115200

€ 244,00

Levigatrice palmare rotorbitale, senza aspirazione. Platorello velcro Ø 150 mm. Corpo in composito, molto leggero ed ergonomico.

Random orbital palm sander, Ø 150 mm velcro pad. Very light and ergonomic composite body.

**€ 31,00****Mod. AC 90**

Cod. 10702110

Platorello velcro Ø 150 mm, 6 fori.
Filetto 5/16" x 24F

Ø 150 mm 6 holes velcro pad.
5/16" x 24F thread

€ 36,00**Cod. 1070211002**

Platorello originale in velcro Ø 150 mm,
senza fori. Filetto 5/16" x 24F

Original Ø 150 mm velcro pad, without
holes. 5/16" x 24F thread

€ 21,00**Mod. AC 91**

Cod. 10702112

Platorello autoadesivo Ø 150 mm, 6
fori. Filetto 5/16" x 24F

Ø 150 mm 6 holes self-stick pad.
5/16" x 24F thread

€ 31,00**Mod. AC 92**

Cod. 10702113

Platorello velcro Ø 125 mm, senza
fori. Filetto 5/16" x 24F

Ø 125 mm velcro pad without
holes. 5/16" x 24F thread

€ 32,00**Mod. AC 93**

Cod. 10702114

Platorello velcro Ø 125 mm, 5
fori. Filetto 5/16" x 24F

Ø 125 mm 5 holes velcro pad.
5/16" x 24F thread

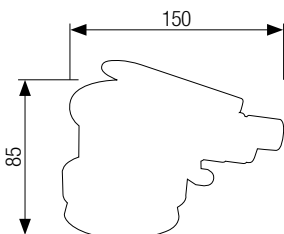

mm	kW	mm	bar		mm	l/sec.	kg	dB(A)	m/sec ²
5	0,19	150	12.000	6,2	1/4" BSPT	8	5,8	76±3	<2,5

SANDERS AND POLISHERS

MOD. 752

Cod. 13117200

€ 380,00

Levigatrice palmare rotorbitale, senza aspirazione. Platorello in velcro \varnothing 150 mm. Corpo in composito, molto leggero, estremamente ergonomico, grazie all'apposito **supporto per il polso**. Il motore pneumatico brevettato a doppia tenuta e privo di lubrificazione consente un **utilizzo senza olio**.

Random orbital palm sander, without suction, for \varnothing 150 mm pad. Very light composite body, extremely ergonomic, thanks to the **special wrist support**. Patented double sealed, lubrication-free air motor provides **oil-free use**.

NEW



OIL FREE



€ 31,00



Mod. AC 90

Cod. 10702110

Platorello velcro \varnothing 150 mm, 6 fori. Filetto 5/16" x 24F

\varnothing 150 mm 6 holes velcro pad. 5/16" x 24F thread

€ 36,00



Cod. 1070211002

Platorello originale in velcro \varnothing 150 mm, senza fori. Filetto 5/16" x 24F

Original \varnothing 150 mm velcro pad, without holes. 5/16" x 24F thread

€ 21,00



Mod. AC 91

Cod. 10702112

Platorello autoadesivo \varnothing 150 mm, 6 fori. Filetto 5/16" x 24F

\varnothing 150 mm 6 holes self-stick pad. 5/16" x 24F thread

€ 31,00



Mod. AC 92

Cod. 10702113

Platorello velcro \varnothing 125 mm, senza fori. Filetto 5/16" x 24F

\varnothing 125 mm velcro pad without holes. 5/16" x 24F thread

€ 32,00



Mod. AC 93

Cod. 10702114

Platorello velcro \varnothing 125 mm, 5 fori. Filetto 5/16" x 24F

\varnothing 125 mm 5 holes velcro pad. 5/16" x 24F thread

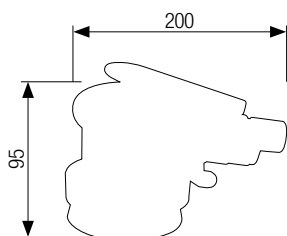

mm	kW	mm	bar	mm	l/sec.	kg	dB(A)	dB(A)	m/sec ²	
5	0,22	150	11.000	6,2	1/4" BSPT	10	0,8	80±3	91±3	0,9

MOD. 532L

Cod. 13115299

€ 300,00

Levigatrice palmare rotorbitale, senza aspirazione, con possibilità di utilizzo a una o due mani. Piattello velcro ø 150 mm. Regolatore dell'aria. Corpo in composito, molto leggero ed ergonomico.

Random orbital palm sander, one or two hand operation. Ø 150 mm velcro pad. Air regulator. Very light and ergonomic composite body.

**€ 31,00****Mod. AC 90**

Cod. 10702110

Piattello velcro ø 150 mm, 6 fori.
Filetto 5/16" x 24F

Ø 150 mm 6 holes velcro pad.
5/16" x 24F thread

€ 36,00**Cod. 1070211002**

Piattello originale in velcro ø 150 mm,
senza fori. Filetto 5/16" x 24F

Original Ø 150 mm velcro pad, without
holes. 5/16" x 24F thread

€ 21,00**Mod. AC 91**

Cod. 10702112

Piattello autoadesivo Ø 150 mm, 6
fori. Filetto 5/16" x 24F

Ø 150 mm 6 holes self-stick pad.
5/16" x 24F thread

€ 31,00**Mod. AC 92**

Cod. 10702113

Piattello velcro Ø 125 mm, senza
fori. Filetto 5/16" x 24F

Ø 125 mm velcro pad without
holes. 5/16" x 24F thread

€ 32,00**Mod. AC 93**

Cod. 10702114

Piattello velcro Ø 125 mm, 5
fori. Filetto 5/16" x 24F

Ø 125 mm 5 holes velcro pad.
5/16" x 24F thread

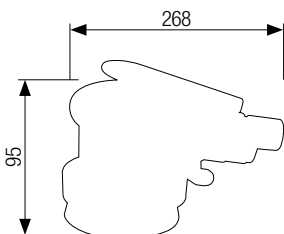

mm	kW	mm	bar	mm	l/sec.	kg	dB(A)	dB(A)	m/sec ²		
5	0,19	150	12.000	6,2	1/4" BSPT	8	5,8	1,00	84±3	90±3	5,6

SANDERS AND POLISHERS

MOD. 533L

Cod. 13115399

€ 320,00

Levigatrice palmare rotorbitale, con aspirazione, con possibilità di utilizzo a una o due mani. Platorello velcro ø 150 mm. Regolatore dell'aria. Corpo in composito, molto leggero ed ergonomico. Possibilità su richiesta di avere il tubo del modello 534 (cod. 4046133SUB).

Dust free random orbital palm sander, one or two hand operation. Ø 150 mm velcro pad. Air regulator. Very light and ergonomic composite body. Hose for the model 534 available on demand (cod. 4046133SUB).



€ 31,00



Mod. AC 90

Cod. 10702110

Platorello velcro ø 150 mm, 6 fori. Filetto 5/16" x 24F

ø 150 mm 6 holes velcro pad. 5/16" x 24F thread

€ 36,00



Cod. 1070211001

Platorello originale in velcro ø 150 mm, 6 fori. Filetto 5/16" x 24F

Original ø 150 mm 6 holes velcro pad. 5/16" x 24F thread

€ 39,00



Mod. AC 90/15

Cod. 10702111

Platorello velcro ø 150 mm, 15 fori. Filetto 5/16" x 24F

ø 150 mm 15 holes velcro pad. 5/16" x 24F thread

€ 21,00



Mod. AC 91

Cod. 10702112

Platorello autoadesivo ø 150 mm, 6 fori. Filetto 5/16" x 24F

ø 150 mm 6 holes self-stick pad. 5/16" x 24F thread

€ 32,00



Mod. AC 93

Cod. 10702114

Platorello velcro Ø 125 mm, 5 fori. Filetto 5/16" x 24F

Ø 125 mm 5 holes velcro pad. 5/16" x 24F thread

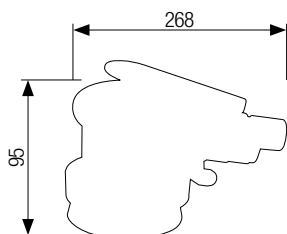

mm	kW	mm	bar	1/4" BSPT	mm	l/sec.	kg	dB(A)	dB(A)	m/sec ²	
5	0,19	150	12.000	6,2	1/4" BSPT	8	5,8	1,00	84±3	90±3	5,6

MOD. 533

€ 264,00

Levigatrice palmare rotorbitale con aspirazione, predisposta per centrali di aspirazione. Platorello velcro Ø 150 mm. Corpo in composito, molto leggero ed ergonomico. Possibilità su richiesta di avere il tubo del modello 534 (cod. 4046133SUB).

Dust free random orbital palm sander with suction system, Ø 150 mm velcro pad. Very light and ergonomic composite body. Hose for the model 534 available on demand (cod. 4046133SUB).

	Mod. 533/25 Cod. 13115325	Mod. 533 Cod. 13115300	Mod. 533/25 B Cod. 13116325	Mod. 533 B Cod. 13116300
Orbita Orbit	2,5	5	2,5	5
Fori Holes	6	6	15	15
€	264,00	264,00	280,00	280,00



€ 31,00

**Mod. AC 90**

Cod. 10702110

Platorello velcro Ø 150 mm, 6 fori.
Filetto 5/16" x 24FØ 150 mm 6 holes velcro pad.
5/16" x 24F thread

€ 36,00

**Cod. 1070211001**Platorello originale in velcro Ø 150 mm, 6
fori. Filetto 5/16" x 24FOriginal Ø 150 mm 6 holes velcro pad.
5/16" x 24F thread

€ 39,00

**Mod. AC 90/15**

Cod. 10702111

Platorello velcro Ø 150 mm, 15 fori.
Filetto 5/16" x 24FØ 150 mm 15 holes velcro pad. 5/16"
x 24F thread

€ 21,00

**Mod. AC 91**

Cod. 10702112

Platorello autoadesivo Ø 150 mm, 6
fori. Filetto 5/16" x 24FØ 150 mm 6 holes self-stick pad.
5/16" x 24F thread

€ 32,00

**Mod. AC 93**

Cod. 10702114

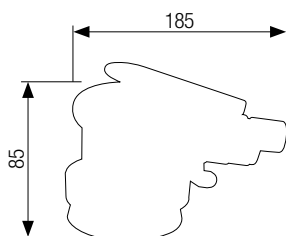
Platorello velcro Ø 125 mm, 5
fori. Filetto 5/16" x 24FØ 125 mm 5 holes velcro pad.
5/16" x 24F thread

mm	kW	mm		bar	mm	l/sec.	kg	dB(A)	dB(A)	m/sec ²
2,5-5-10	0,19	150	12.000	6,2	1/4" BSPT	8	5,8	76±3	88±3	<2,5

SANDERS AND POLISHERS

MOD. 753

Cod. 13117300

€ 400,00

Levigatrice palmare rotorbitale con aspirazione. Platorello in velcro ø 150 mm. Corpo in composito, molto leggero, estremamente ergonomico, grazie all'apposito **supporto per il polso**. Il motore pneumatico brevettato a doppia tenuta e privo di lubrificazione consente un **utilizzo senza olio**.

Dust free random orbital palm sander, with suction system, for ø 150 mm pad. Very light composite body, extremely ergonomic, thanks to the **special wrist support**. Patented double sealed, lubrication-free air motor provides **oil-free use**.

NEW



OIL FREE



€ 31,00



Mod. AC 90

Cod. 10702110

Platorello velcro ø 150 mm, 6 fori.
Filetto 5/16" x 24F

ø 150 mm 6 holes velcro pad.
5/16" x 24F thread

€ 36,00



Cod. 1070211001

Platorello originale in velcro ø 150 mm, 6 fori. Filetto 5/16" x 24F

Original ø 150 mm 6 holes velcro pad.
5/16" x 24F thread

€ 39,00



Mod. AC 90/15

Cod. 10702111

Platorello velcro ø 150 mm, 15 fori.
Filetto 5/16" x 24F

ø 150 mm 15 holes velcro pad. 5/16" x 24F thread

€ 21,00



Mod. AC 91

Cod. 10702112

Platorello autoadesivo ø 150 mm, 6 fori. Filetto 5/16" x 24F

ø 150 mm 6 holes self-stick pad.
5/16" x 24F thread

€ 32,00



Mod. AC 93

Cod. 10702114

Platorello velcro ø 125 mm, 5 fori. Filetto 5/16" x 24F

ø 125 mm 5 holes velcro pad.
5/16" x 24F thread

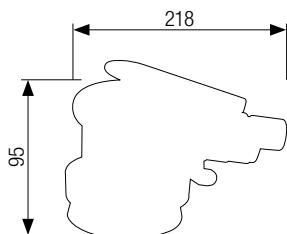

mm	kW	mm	mm	bar	mm	l/sec.	kg	dB(A)	m/sec ²
5	0,22	150	11.000	6,2	1/4" BSPT	10	0,80	80±3	0,9

MOD. 534

Cod. 13115400

€ 260,00

Levigatrice palmare rotorbitale con aspirazione, completa di sacchetto e piatto velcro Ø 150 mm a 6 fori. Corpo in composito, molto leggero ed ergonomico.

Dust free random orbital palm sander, complete with hose and bag and Ø 150 mm 6 holes velcro pad. Very light and ergonomic composite body.

**€ 31,00****Mod. AC 90**

Cod. 10702110

Piatto velcro Ø 150 mm, 6 fori.
Filetto 5/16" x 24F

Ø 150 mm 6 holes velcro pad.
5/16" x 24F thread

€ 36,00**Cod. 1070211001**

Piatto originale in velcro Ø 150 mm, 6 fori. Filetto 5/16" x 24F

Original Ø 150 mm 6 holes velcro pad.
5/16" x 24F thread

€ 39,00**Mod. AC 90/15**

Cod. 10702111

Piatto velcro Ø 150 mm, 15 fori.
Filetto 5/16" x 24F

Ø 150 mm 15 holes velcro pad. 5/16" x 24F thread

€ 21,00**Mod. AC 91**

Cod. 10702112

Piatto autoadesivo Ø 150 mm, 6 fori. Filetto 5/16" x 24F

Ø 150 mm 6 holes self-stick pad.
5/16" x 24F thread

€ 32,00**Mod. AC 93**

Cod. 10702114

Piatto velcro Ø 125 mm, 5 fori. Filetto 5/16" x 24F

Ø 125 mm 5 holes velcro pad.
5/16" x 24F thread

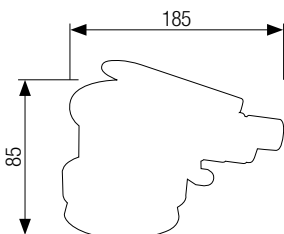

mm	kW	mm		bar	mm	l/sec.	kg	dB(A)	dB(A)	m/sec ²	
5	0,19	150	12.000	6,2	1/4" BSPT	8	5,8	0,80	76±3	88±3	<2,5

SANDERS AND POLISHERS

MOD. 474

Cod. 13116500

€ 140,00

Levigatrice ad azione orbitale, che utilizza un paltorello 93 x 165 mm, con pinze a molla.

Orbital block sander, using a 93 x 165 mm pad, with spring clips.

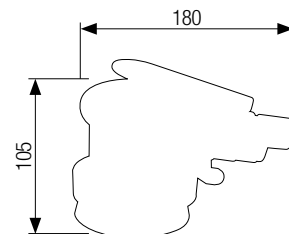

mm	mm		bar	1/4" BSPT	mm	l/sec.	kg	dB(A)	dB(A)	m/sec ²
4	93x165	8.500	6,2	1/4" BSPT	10	6,5	1,90	87±3	98,5±3	3,0

MOD. 420

Cod. 13117810

€ 250,00

Levigatrice angolare filetto M14. Regolatore dell'aria e scarico in avanti. Paltorello flessibile Ø180 mm in dotazione.

Angle sander with M14 thread. Equipped with air regulator, air exhaust forward and flexible Ø 180 mm pad.

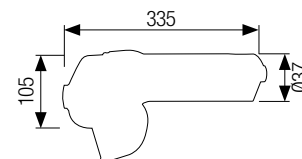

kW	mm		bar	1/4" BSPT	mm	l/sec.	kg	dB(A)	dB(A)	m/sec ²
0,45	171x22	4.500	6,2	1/4" BSPT	10	8,3	2,00	85,7±3	96,7±3	<2,5

MOD. 421

Cod. 13117821

€ 260,00

Lucidatrice/Levigatrice angolare filetto M14. Regolatore dell'aria e scarico in avanti. Paltorello flessibile Ø180 mm in dotazione.

Angle polisher with M14 thread. Equipped with air regulator, air exhaust forward and flexible Ø 180 mm pad.



Mod. AC 95
Cod. 10702070 € 38,00

Cuffia in lana 7" per pulitrici/lucidatrici, attacco in velcro.
7" wool polishing velcro pad.

Mod. AC 96 (5/8"W)
Cod. 10702080 € 51,00

Mod. AC 96/14 (M14)
Cod. 10702082 € 51,00

Paltorello velcro Ø180 mm per cuffia di lana.
Ø 180 mm velcro pad for wool polishing pad.

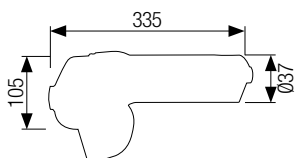

kW	mm		bar	1/4" BSPT	mm	l/sec.	kg	dB(A)	dB(A)	m/sec ²
0,45	171x22	2.400	6,2	1/4" BSPT	10	8,3	2,00	94±3	105±3	<2,5

MOD. 475

Cod. 13112500

€ 110,00



Levigatrice veloce con regolatore d'aria. Filetto 7/16". Fornita con piatello flessibile Ø 125 mm.

High speed die grinder equipped with air regulator. 7/16" thread. Supplied with flexible Ø 125 mm pad.

KW	mm	mm	bar	mm	l/sec.	kg	dB(A)	dB(A)	m/sec ²	
0,40	125x22	20.000	6,2	1/4" NPT	10	10,0	1,30	93±3	106±3	<2,5

MOD. 526

Cod. 13117815

€ 390,00

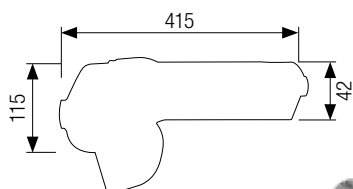

Levigatrice angolare per lavori gravosi, con filetto M14. Dotata di regolatore incorporato, scarico posteriore dell'aria e maniglia laterale utilizzabile su entrambi i lati. Piatello flessibile Ø 180 mm in dotazione. Ideale per la levigatura di metallo e stucco per carrozzeria, la rimozione della ruggine e praticamente tutte le levigature di superfici automobilistiche.

Heavy duty angle sander with M14 thread. Equipped with built-in regulator, rear air exhaust and side handle that fits on either side. Flexible Ø 180 mm pad included. Ideal tool for sanding of metal and body filler, rust removal, and virtually all automotive smoothing of surfaces.



KW	mm	mm	bar	mm	l/sec.	kg	dB(A)	dB(A)	m/sec ²	
0,50	180	4.200	6,2	1/4" BSPT	10	8,6	2,90	81±3	91±3	<2,5

MOD. 527

Cod. 13117825

€ 410,00



Lucidatrice angolare per lavori gravosi, con filetto M14. Dotata di regolatore incorporato, scarico posteriore dell'aria e maniglia laterale utilizzabile su entrambi i lati. Piatello flessibile Ø 180 mm in dotazione. Ideale per la lucidatura di vernice, metallo o plastica.

Heavy duty angle polisher with M14 thread. Equipped with built-in regulator, rear air exhaust and side handle that fits on either side. Flexible Ø 180 mm pad included. Ideal tool for buffing and polishing paint, metal or plastic.



Mod. AC 95
Cod. 10702070 € 38,00

Cuffia in lana 7" per pulitrici/lucidatrici, attacco in velcro.
7" wool polishing velcro pad.



Mod. AC 96/14 (M14)
Cod. 10702082 € 51,00

Piatello velcro Ø180 mm per cuffia di lana.
Ø 180 mm velcro pad for wool polishing pad.

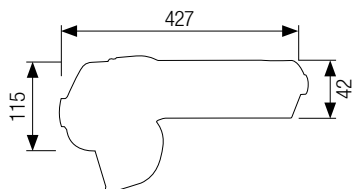

KW	mm	mm	bar	mm	l/sec.	kg	dB(A)	dB(A)	m/sec ²	
0,50	180	2.200	6,2	1/4" BSPT	10	8,6	2,90	90±3	102±3	<2,5

SANDERS AND POLISHERS

MOD. 427

Cod. 13200470

€ 580,00

Levigatrice angolare multifunzione. Utensile dotato di protezione, leva di avviamento di sicurezza e scarico posteriore.

Multifunctional angle grinder. Equipped with safety guard, safety throttle lever and rear exhaust.



Il kit comprende: Kit contents:



AC 427/1 4042700511
Spazzola metallica fine 11 mm
11 mm fine wire brush
€ 21,00



AC 427/2 4042700523
Spazzola metallica fine 23 mm
23 mm fine wire brush
€ 21,00



AC 427/3 4042700711
Spazzola metallica grossa 11 mm
11 mm coarse wire brush
€ 21,00



AC 427/4 4042700723
Spazzola metallica grossa 23 mm
23 mm coarse wire brush
€ 21,00



AC 427/5 404270903R
Disco per rimozione adesivi
Rubber eraser
€ 30,00



AC 427/6 40427903RW
Disco per rimozione vernici a base acqua
Water based paint rubber eraser
€ 30,00



AC 427/7 4042700902
Spazzola in rete di fibre sintetiche
Black stripping wheel
€ 25,00



AC 427/8 404270903A
Adattatore per spazzola 11 mm
Adaptor for 11 mm wire brush
€ 25,00



AC 427/9 40427903AA
Adattatore per spazzola 23 mm e disco rimozione adesivi/vernici.
Adaptor for rubber eraser and 23 mm wire brush
€ 25,00



AC 427/10 404270902S
Adattatore per singole spazzole in fibre sintetiche.
Adaptor for single black stripping wheel
€ 25,00



AC 427/11 404270902D
Adattatore per doppie spazzole in fibre sintetiche.
Adaptor for double black strip wheels
€ 25,00

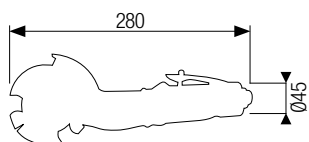

KW										
kW	mm	rpm	bar	1/4" BSPT	mm	l/sec.	kg	dB(A)	dB(A)	m/sec ²
0,45	100	3.500	6,2	1/4" BSPT	10	11,6	1,20	88±3	94±3	4,4



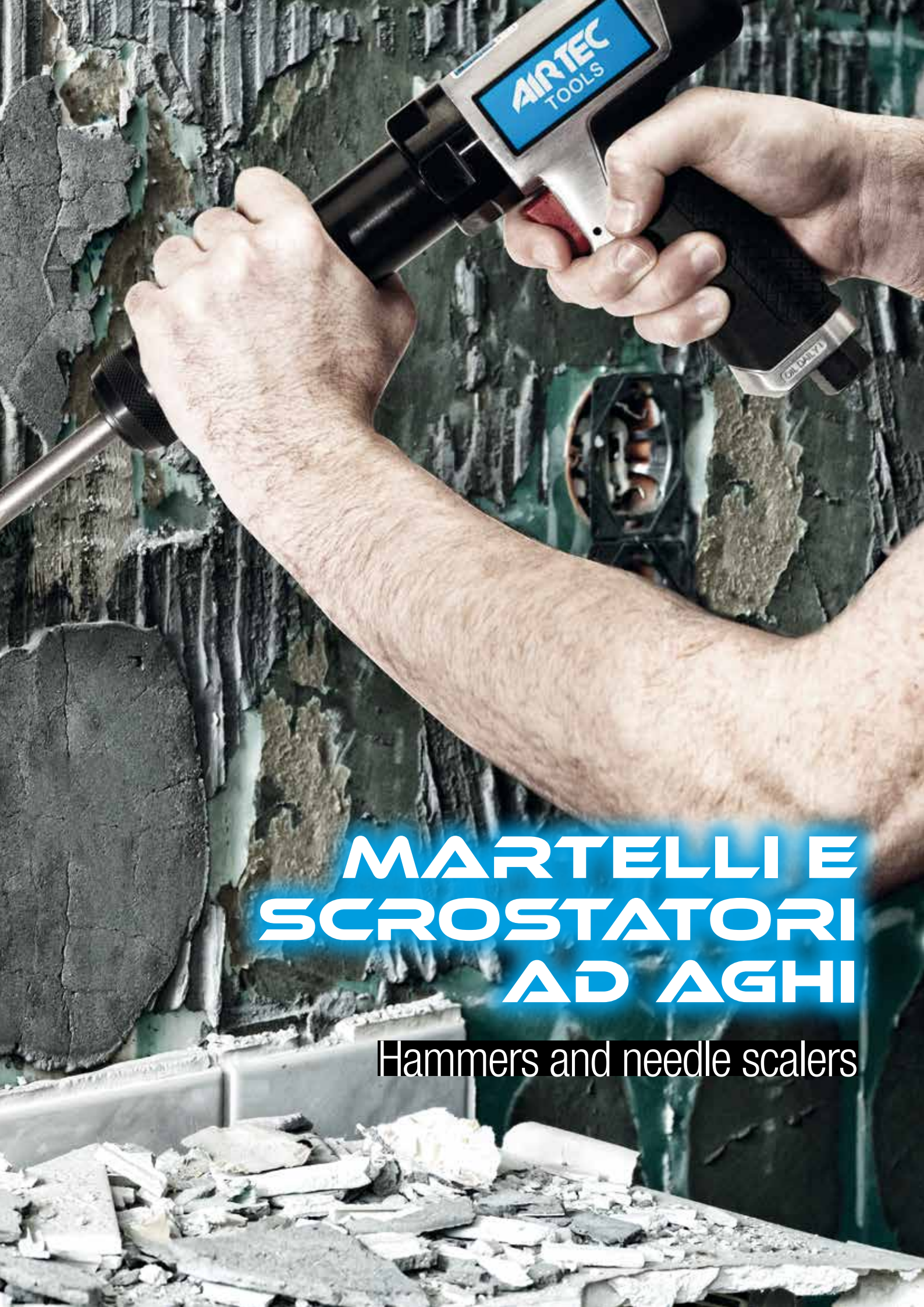

MARTELLI E SCROSTATORI AD AGHI

Hammers and needle scalers

MOD. 200

Cod. 14000035

€ 220,00

Martello pneumatico attacco esagonale. Idoneo per l'utilizzo pesante e continuativo. Fornito in valigetta con 5 scalpelli, molla trattenimento e trattenitore.

Heavy-duty hexagonal air hammer. In blow mould case, complete with 5 chisels, quick change retainer and retainer spring.

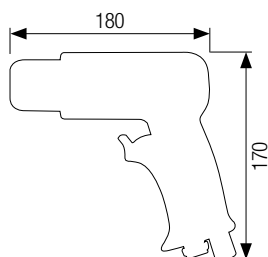

€ 30,00

Mod. AC 9
Cod. 17509000

Trattenitore per scalpelli.
Quick change retainer.



€ 3,50 cad.

Mod. AC 11
Cod. 4010104042

Molla trattenimento. Confezione tassativa 10 pz.
Retainer spring, 10 pcs per pack.

Scalpelli esagonali Ø 10 mm
Ø 10 mm hexagonal chisels

Cod. 10600179
€ 12,00
Cod. 10600279
€ 18,00
Cod. 10600379
€ 11,00
Cod. 10600579
€ 11,00
Cod. 10600679
€ 11,00



Mod. AC 200
Cod. 10600020
€ 40,00 cad.

Serie scalpelli esagonali Ø 10 mm
Ø 10 mm hexagonal chisels set



J		HZ								
Joule	mm	bar		mm	l/sec.	kg	dB(A)	dB(A)	m/sec ²	
7,0	10	3.000	6,2	1/4" BSPT	10	8,3	1,70	96±3	110±3	5,8

MOD. 479

Cod. 14000010

€ 140,00

Martello pneumatico attacco esagonale, dotato di regolatore di potenza. Completo di 5 scalpelli e molla trattenimento.

Hexagonal air hammer, with progressive power regulator. Equipped with 5 chisels and retainer spring.

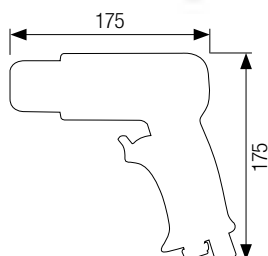

€ 30,00

Mod. AC 9
Cod. 17509000

Trattenitore per scalpelli.
Quick change retainer.



€ 3,50 cad.

Mod. AC 11
Cod. 4010104042

Molla trattenimento. Confezione tassativa 10 pz.
Retainer spring, 10 pcs per pack.

Scalpelli esagonali Ø 10 mm
Ø 10 mm hexagonal chisels

Cod. 10600179
€ 12,00
Cod. 10600279
€ 18,00
Cod. 10600379
€ 11,00
Cod. 10600579
€ 11,00
Cod. 10600679
€ 11,00



J		HZ								
Joule	mm	bar		mm	l/sec.	kg	dB(A)	dB(A)	m/sec ²	
5,3	10	3.500	6,2	1/4" BSPT	10	8,3	1,50	99±3	110,9±3	7,4

HAMMERS AND NEEDLE SCALERS

MOD. 203

Cod. 14000045

€ 280,00

Martello pneumatico attacco esagonale, per lavori gravosi. Con doppi cuscinetti per assorbire urti e vibrazioni. Fornito in valigetta con 5 scalpelli, molla trattenimento e trattenitore.

Heavy-duty hexagonal air hammer, with dual cushions to absorb shocks and vibrations. In blow mould case, complete with 5 chisels, quick change retainer and retainer spring.



€ 30,00

Mod. AC 9
Cod. 17509000

Trattenitore per scalpelli.
Quick change retainer.



€ 3,50 cad.

Mod. AC 11
Cod. 4010104042

Molla trattenimento. Confezione tassativa 10 pz.
Retainer spring. 10 pcs per pack.

Scalpelli esagonali Ø 10 mm
Ø 10 mm hexagonal chisels

Cod. 10600179
€ 12,00
Cod. 10600279
€ 18,00
Cod. 10600379
€ 11,00
Cod. 10600579
€ 11,00
Cod. 10600679
€ 11,00



Mod. AC 200
Cod. 10600020
€ 40,00 cad.

Serie scalpelli esagonali Ø 10 mm
Ø 10 mm hexagonal chisels set

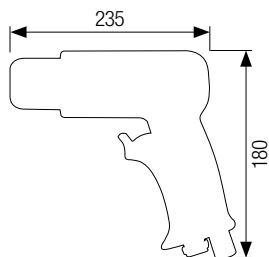

J	mm	HZ	bar	mm	l/sec.	kg	dB(A)	dB(A)	m/sec ²	
9,2	10	2.500	6,2	1/4" BSPT	8	7,5	2,60	100±3	109±3	7,39

MOD. 205

Cod. 14000050

€ 250,00

Scalpellatore pneumatico dritto, con sistema di tenuta dello scalpello con sfera. Scalpello piegato 35 mm in dotazione.

Air flux chipper with chisel holding system with ball. 35 mm bent chisel supplied with the tool.



€ 26,00



Mod. AC 205/1
Cod. 10600800

Scalpello piegato 35 mm
35 mm bent chisel

€ 26,00



Mod. AC 205/2
Cod. 10600805

Scalpello piatto 20 mm
20 mm flat chisel

€ 26,00



Mod. AC 205/3
Cod. 10600810

Scalpello a punta
Point chisel

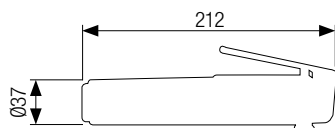

J	mm	HZ	bar	mm	l/sec.	kg	dB(A)	dB(A)	m/sec ²	
7,0	12,5	5.000	6,2	1/4" BSPT	10	3,3	1,80	98±3	109±3	31±3

MOD. 222

Cod. 14001000

€ 500,00

Martello da taglio esagonale con corsa di 3" per lavori gravosi. Design ergonomico e robusta struttura a quattro bulloni per un utilizzo intensivo. Speciale trattamento termico di cilindro e pistone per una maggiore durata. Ideale per la manutenzione degli impianti di fonderia e per lavori di edilizia.

3" stroke hexagonal chipping hammer for heavy-duty jobs. Ergonomically design and rugged four bolt construction for heavy duty use. Heat treated precision cylinder and piston for long life. Best for foundry plant maintenance and general contractor work.



€ 30,00



Mod. AC 222/1

Cod. 10600821

Scalpello a punta. Lunghezza 260 mm. Gambo 14,7 mm.

Moil chisel. 260 mm length. 14,7 mm hex shank.

€ 30,00



Mod. AC 222/2

Cod. 10600822

Scalpello piatto 20 mm. Lunghezza 260 mm. Gambo 14,7 mm.

20 mm flat chisel. 260 mm length. 14,7 mm hex shank.

€ 30,00



Mod. AC 222/3

Cod. 10600823

Scalpello piatto 30 mm. Lunghezza 260 mm. Gambo 14,7 mm.

30 mm flat chisel. 260 mm length. 14,7 mm hex shank.

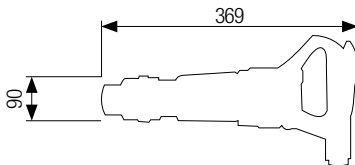

J		HZ								
Joule	mm	Hz	bar	mm	l/sec.	kg	dB(A)	dB(A)	m/sec ²	
21,3	14,7	2.300	6,2	3/8"PT	13	3,0	7,70	98±3	109±3	15,73

MOD. 210

Cod. 14002000

€ 350,00

Scrostatore ad aghi con impugnatura dritta. Dotato di manico regolabile per adattare la lunghezza degli aghi al lavoro da svolgere.

Straight version needle scaler. Equipped with adjustable coupling to adapt the length of the needles to the task.



Mod. AC 210

Cod. 17600010 € 23,00

Set aghi di ricambio (19 aghi 18 cm - Ø 3 mm)

Replacement needles set (19 needles 18 cm - Ø 3 mm)

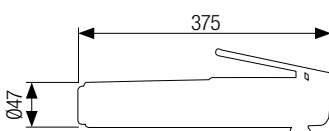

J		HZ								
Joule	Nr	Hz	bar	mm	l/sec.	kg	dB(A)	dB(A)	m/sec ²	
8,0	19(Ø3 mm)	3.000	6,2	1/4" BSPT	8	4,0	2,60	97±3	107,8±3	8,7

HAMMERS AND NEEDLE SCALERS

MOD. 211

Cod. 14002010

€ 370,00

Scrostatore ad aghi con impugnatura a pistola. Dotato di manicotto regolabile per adattare la lunghezza degli aghi al lavoro da svolgere.

Pistol version needle scaler. Equipped with adjustable coupling to adapt the length of the needles to the task.



Mod. AC 210
Cod. 17600010 € 23,00

Set aghi di ricambio (19 aghi 18 cm - Ø 3 mm)
Replacement needles set (19 needles 18 cm - Ø 3 mm)

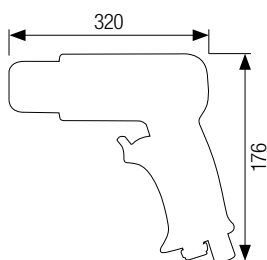

J	Nr	HZ	bar	mm	l/sec.	kg	dB(A)	dB(A)	m/sec ²	
7,0	19 (Ø 3 mm)	3.000	6,2	1/4" BSPT	8	4,0	2,60	97±3	107,8±3	8,7

MOD. 212

Cod. 14002020

€ 400,00

Scrostatore ad aghi con impugnatura a pistola, per lavori gravosi. Dotato di manicotto regolabile per adattare la lunghezza degli aghi al lavoro da svolgere.

Heavy duty pistol grip needle scaler. Equipped with adjustable coupling to adapt the length of the needles to the task.

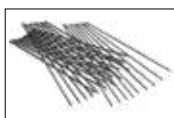

Mod. AC 212
Cod. 17600020 € 33,00

Set aghi di ricambio (28 aghi 18 cm - Ø 3 mm)
Replacement needles set (28 needles 18 cm - Ø 3 mm)

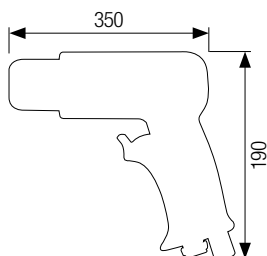

J	Nr	HZ	bar	mm	l/sec.	kg	dB(A)	dB(A)	m/sec ²	
11,0	28 (Ø 3 mm)	2.700	6,2	1/4" BSPT	10	6,0	3,90	102±3	113±3	9,8



A hand is shown using a cutting tool on the engine of a car. The background is a blue digital overlay with glowing lines and particles. The text 'UTENSILI DA TAGLIO' is written in large, bold, white letters with a blue glow, and 'Cutting tools' is written in smaller, white letters below it.

UTENSILI DA TAGLIO

Cutting tools

MOD. 553

Cod. 16300001

€ 210,00

Seghetto alternativo dotato di tubo di scarico posteriore, completo di una lama per acciaio (32T) e una per alluminio (24T). Corsa della lama 10 mm.

Reciprocating saw equipped with rear air exhaust hose and one blade for steel (32T) and one for aluminium (24T). 10 mm blade stroke.



Lame per seghetto alternativo
confezione da 10 pezzi - Lunghezza: 95 mm. Taglio: 50 mm
Attacco lama: 12,5 x 1 mm.

Blades for reciprocating saw
10 pcs box - Length: 95 mm. Cut: 50 mm.
Blade connection: 12,5 x 1 mm.



Mod. AC 20
Cod. 10700120
€ 4,50 cad.
32 denti - acciaio
32 teeth - steel



Mod. AC 21
Cod. 10700121
€ 4,50 cad.
24 denti - alluminio
24 teeth - aluminum



Mod. AC 22
Cod. 10700122
€ 4,50 cad.
18 denti - legno
18 teeth - wood

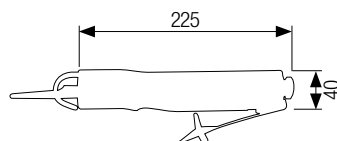

HZ							
	bar	1/4" BSPT	mm	l/sec.	kg	dB(A)	m/sec ²
9.000	6,2	1/4" BSPT	8	4,0	0,80	87,5±3	94,6±3

MOD. 554

Cod. 16300003

€ 195,00

Seghetto alternativo, completo di una lama per acciaio (32T) e una per alluminio (24T). Corsa della lama 10 mm.

Reciprocating saw equipped with one blade for steel (32T) and one for aluminium (24T). 10 mm blade stroke.



Lame per seghetto alternativo
confezione da 10 pezzi - Lunghezza: 95 mm.
Taglio: 50 mm. Attacco lama: 12,5 x 1 mm.

Blades for reciprocating saw
10 pcs box - Length: 95 mm. Cut: 50 mm.
Blade connection: 12,5 x 1 mm.



Mod. AC 20
Cod. 10700120
€ 4,50 cad.
32 denti - acciaio
32 teeth - steel



Mod. AC 21
Cod. 10700121
€ 4,50 cad.
24 denti - alluminio
24 teeth - aluminum



Mod. AC 22
Cod. 10700122
€ 4,50 cad.
18 denti - legno
18 teeth - wood

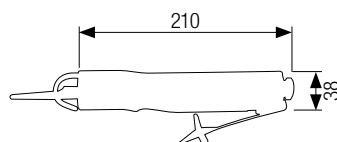

HZ							
	bar	1/4" BSPT	mm	l/sec.	kg	dB(A)	m/sec ²
9.000	6,2	1/4" BSPT	6	2,9	0,60	87±3	100±3

CUTTING TOOLS

MOD. 559/S

Cod. 16300010

€ 350,00

NEW

Seghetto alternativo pneumatico 0,5 HP, a basse vibrazioni, con scarico posteriore dell'aria. Funzione a doppia velocità e motore che permette di tagliare sia l'acciaio, sia materiali morbidi quali legno, plastica e alluminio. **Adatto solo a lame con foro ed è dotato di un pratico meccanismo di bloccaggio/sbloccaggio della lama, senza bisogno di accessori.** In dotazione una lama 14T (legno/plastica) e una lama 18T (alluminio).

Low vibration 0,5 HP reciprocating air saw, with rear air exhaust. Built in dual-speed design and motor that allow cutting both steel and soft materials (wood, plastic and aluminium). **Only suitable for blades with hole. Equipped with a practical locking/unlocking mechanism for the blade, without the need of accessories.** Supplied with one 14T blade (wood/plastic) and one 18T blade (aluminium).



Lame con foro per seghetto. Confezione da 10 pezzi
- Lunghezza: 150 mm Taglio: 115 mm Attacco lama:
12,5 x 1 mm.

Blades with hole for saw. 10 pcs box Length:
150 mm Cut: 115 mm
Blade connection: 12,5 x 1 mm.

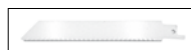

Mod. AC 559/1
Cod. 10700130
€ 5,00 cad.
24 denti - acciaio
24 teeth - steel



Mod. AC 559/2
Cod. 10700131
€ 5,00 cad.
18 denti - alluminio
18 teeth - aluminium



Mod. AC 559/3
Cod. 10700132
€ 5,00 cad.
14 denti - legno/plastica
14 teeth - wood/plastic

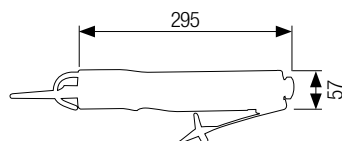

HZ								
	bar	mm	l/sec.	kg	dB(A)	dB(A)	m/sec ²	
5.000	6,2	1/4" BSP	10	1,8	0,95	85±3	90±3	11,8

MOD. 557/K

Cod. 16300007

€ 320,00

Seghetto pneumatico che può essere utilizzato anche come limatrice pneumatica. Le lime devono avere un diametro del gambo di 4 mm e una corsa di 10 mm. Il kit è fornito in valigetta comprendente 5 lime, 5 lame a 24 denti (24T) e 5 lame a 32 denti (32T).

Air saw that can be also used as air filer. The files must have a max shank diameter of 4 mm and a stroke length of 10 mm. In blow mould case, equipped with 5 pcs files, 5 pcs 24T blades and 5 pcs 32T blades.

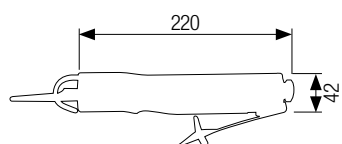

Lime ø 4 mm
Ø 4 mm files



Mod. AC 20
Cod. 10700120
€ 4,50 cad.
32 denti - acciaio
32 teeth - steel

Mod. AC 21
Cod. 10700121
€ 4,50 cad.
24 denti - alluminio
24 teeth - aluminium

Mod. AC 22
Cod. 10700122
€ 4,50 cad.
18 denti - legno
18 teeth - wood

AC 557/1
Cod. 10700141 **€ 15,00**
AC 557/2
Cod. 10700142 **€ 15,00**
AC 557/3
Cod. 10700143 **€ 15,00**
AC 557/4
Cod. 10700144 **€ 15,00**
AC 557/5
Cod. 10700145 **€ 15,00**

HZ								
	bar	mm	l/sec.	kg	dB(A)	dB(A)	m/sec ²	
5.000	6,2	1/4" BSPT	10	2,0	1,10	86±3	96,1±3	4,2

MOD. 565

Cod. 16301000

€ 200,00

Limatrice pneumatica, dotata di gancio di sospensione e attacco aria girevole. In dotazione 4 lime. Attacco tondo Ø 6 mm. Corsa della lama 10 mm.

Air filer, equipped with hook and swivel air inlet. Supplied with 4 limes. Ø 6 mm round attachment. 10 mm blade stroke.



Lime Ø 6 mm
Ø 6 mm files



AC 565/1 € 16,00
Cod. 4040308023

AC 565/2 € 16,00
Cod. 4040308024

AC 565/3 € 16,00
Cod. 4040308025

AC 565/4 € 16,00
Cod. 4040308026

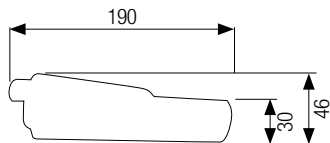

HZ								
	bar	1/4" BSPT	mm	l/sec.	kg	dB(A)	dB(A)	m/sec ²
3.700	6,2	1/4" BSPT	8	4,2	1,00	84,5±3	95±3	0,3

MOD. 571

Cod. 16303000

€ 150,00

Roditrice pneumatica di ingombro ridotto ed ottima maneggevolezza. Indicato per eseguire tagli su lamiere, rivestimenti o ogni altro materiale di piccolo spessore (fino a 1,5 mm di spessore).

Air nibbler, particularly handy considering the compact size and the low weight. Indicated to cut metal sheets, coatings or any other material of small thickness (up to 1,5 mm thick).

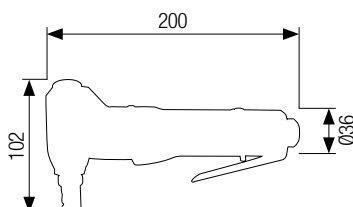

HZ								
	bar	1/4" BSPT	mm	l/sec.	kg	dB(A)	dB(A)	m/sec ²
3.500	6,2	1/4" BSPT	10	6,0	0,80	92±3	103±3	10,5

CUTTING TOOLS

MOD. 567

Cod. 16302000

€ 170,00

Cesoia pneumatica a pistola, con capacità di taglio da 1,1 mm.
Scarico nel manico.

Pistol type air shear, with 1,1 mm cutting capacity. Exhaust through the handle.

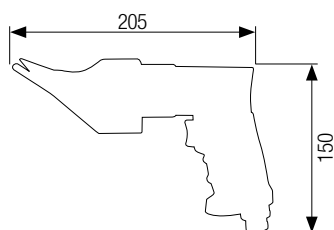

bar	mm	l/sec.	kg	dB(A)	dB(A)	m/sec ²		
2,800	6,2	1/4" BSPT	10	2,0	1,30	85±3	96±3	3,4

MOD. 568

Cod. 16302005

€ 170,00

Cesoia pneumatica dritta, con capacità di taglio da 1,2 mm.
Regolatore dell'aria sul corpo, attacco aria girevole e scarico posteriore.
Rivestimento ergonomico in gomma.

Straight air shear, with 1,2 mm cutting capacity. Air regulator on top, swivel air inlet and rear exhaust. Ergonomic ABS sleeve.

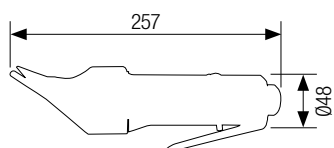

bar	mm	l/sec.	kg	dB(A)	dB(A)	m/sec ²		
2,500	6,2	1/4" BSPT	10	2,0	1,10	80,3±3	91,3±3	3,2

RIVETTATRICI

Riveting guns





MOD. 410

Cod. 16043000

€ 500,00

Rivettatrice idropneumatica in composito, con interruttore di comando di aspirazione e contenitore di raccolta. Adatta per rivetti ciechi/a strappo standard da 2,4 a 4,8 mm in tutti i materiali.

Composite air hydraulic riveter with suction control switch and collection bottle. Riveter capacity: 2,4 - 4,8 mm. Tools suitable for standard blind rivets in all materials.

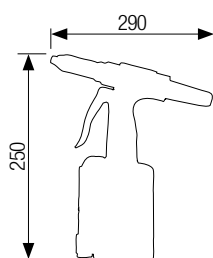

Corsa Strike	Forza trazione Pulling power									
mm	kg	mm	bar		mm	l/sec.	kg	dB(A)	dB(A)	m/sec ²
15	908	da 2,4 a 4,8	6,2	1/4" NPT	6	2,0	1,45	72,8±3	83,8±3	<2,5

MOD. 413

Cod. 16045000

€ 220,00

Rivettatrice idropneumatica a pistola. Capacità rivetti: 2,4 – 4,8 mm. Utensile adatto per rivetti ciechi/a strappo standard in alluminio o rame.

Air hydraulic riveter. Riveter capacity: 2,4 – 4,8 mm. Tool suitable for aluminum or copper standard blind rivets.

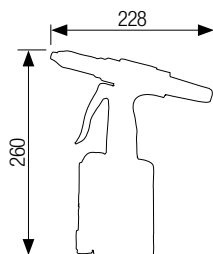

Corsa Strike	Forza trazione Pulling power									
mm	kg	mm	bar		mm	l/sec.	kg	dB(A)	dB(A)	m/sec ²
14	850	da 2,4 a 4,8	6,2	1/4" NPT	6	2,0	1,45	76±3	88±3	<2,5

RIVETING GUNS

MOD. 414

Cod. 16046000

€ 900,00

Rivettatrice idropneumatica in composito, con interruttore di comando di aspirazione e contenitore di raccolta. Adatta per rivetti ciechi/a strappo standard da 3,2 a 7,9 mm in tutti i materiali.

Composite air hydraulic riveter with suction control switch and collection bottle. Riveter capacity: 3,2 - 7,9 mm. Tools suitable for standard blind rivets in all materials.

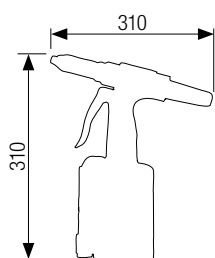

Corsa Strike	Forza trazione Pulling power									
mm	kg	mm	bar		mm	l/sec.	kg	dB(A)	dB(A)	m/sec ²
22,5	1.723	da 3,2 a 7,9	6,2	1/4" NPT	6	2,0	1,88	75,5±3	86,5±3	<2,5

MOD. 412

Cod. 16044100

€ 530,00

Rivettatrice idropneumatica a pistola, alte prestazioni. Capacità rivetti: 2,4 - 6,4 mm. Utensile adatto per rivetti ciechi/a strappo standard in alluminio o rame.

Heavy-duty air hydraulic riveter. Riveter capacity: 2,4 - 6,4 mm. Tool suitable for aluminum or copper standard blind rivets.

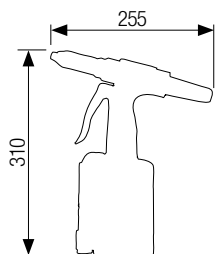

Corsa Strike	Forza trazione Pulling power									
mm	kg	mm	bar		mm	l/sec.	kg	dB(A)	dB(A)	m/sec ²
18,5	1.248	da 2,4 a 6,4	6,2	1/4" NPT	6	2,0	2,10	78±3	90±3	<2,5

UTENSILI VARI

Various tools

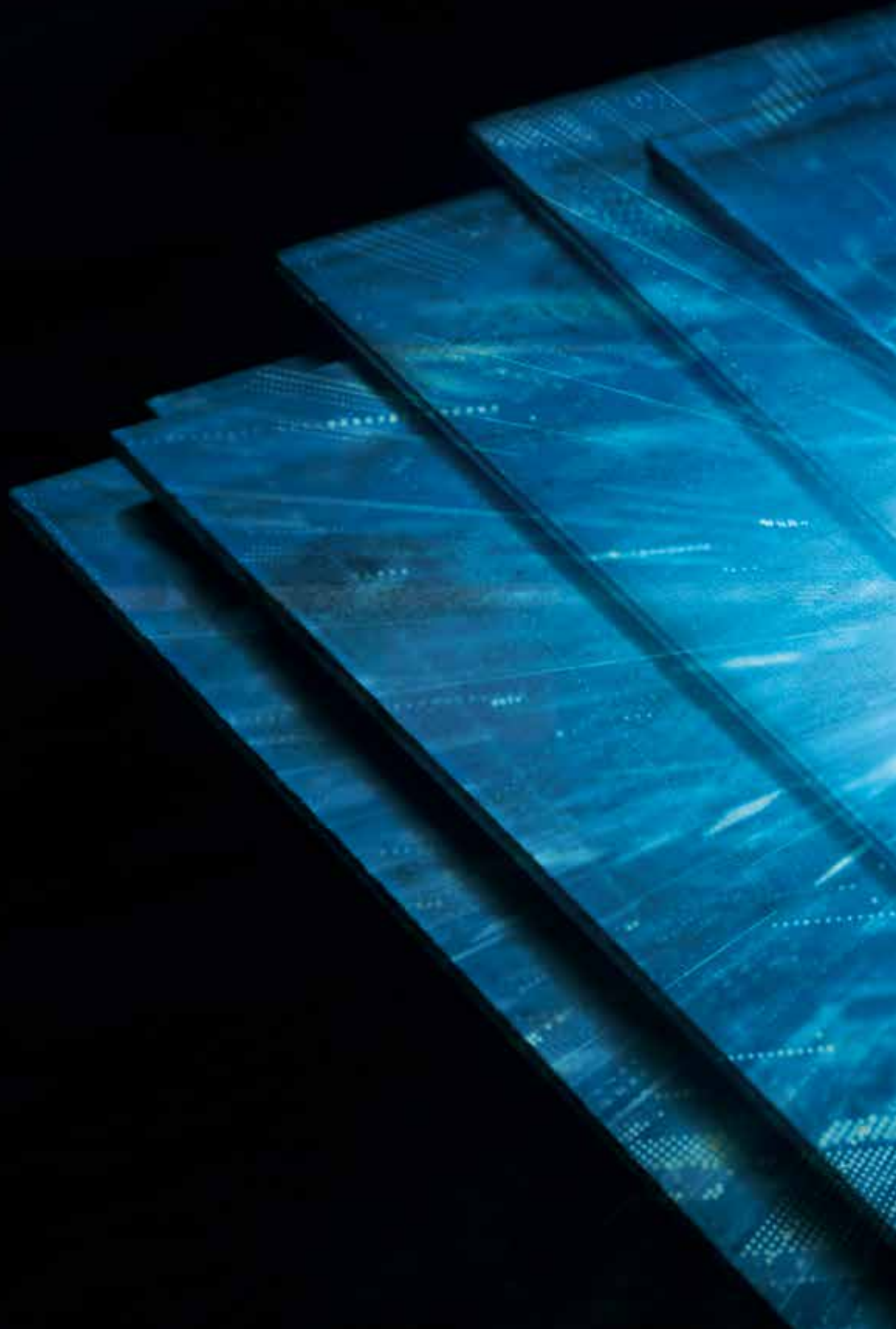



MOD. 900





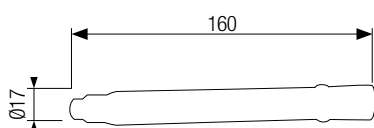

Cod. 15100000

€ 200,00

Penna marcatrice con punta al carburo di tungsteno. Adatta per scrivere su superfici lisce, di metallo, acciaio temperato e inox, lamiera, plastica, pietra e marmo.

Engraving pen with tungsten carbide tip. For use on smooth, metal, tempered and stainless steel, sheet, plastic, stone and marble surfaces.



HZ							
	bar		mm	l/sec.	kg	dB(A)	m/sec ²
34.000	6,2	1/4" BSPT	8	2,0	0,24	75±3	2,9

MOD. 550





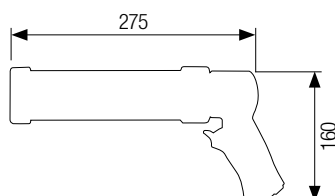

Cod. 16200000

€ 65,00

Pistola pneumatica per silicone, collanti, sigillanti, ecc. di media densità. Da utilizzare con cartucce standard fino a 400 g (50 x 215 mm) rigide o morbide.

Caulking gun for silicone, adhesives, sealants, etc. medium density. For use with rigid or soft standard cartridges up to 400 g (50 x 215 mm).



						
bar		mm	l/sec.	kg	dB(A)	m/sec ²
6,2	1/4" BSPT	6	0,8 (x corsa)	1,10	74±3	<2,5

MOD. 562

Cod. 16400030









€ 370,00

Coltello oscillante per parabrezza, dotato di tubo di scarico posteriore. Completo di 3 lame (G 35-25, U25 e G 90-58).







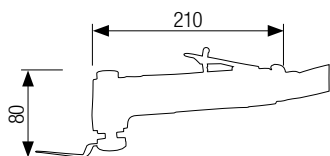

Window cutter for windscreen equipped with back air exhaust hose. Complete with 3 blades (G 35-25, U25 and G 90-58).



Lame per coltello oscillante - Attacco esagonale 19 mm.
Blades for window cutter - 19 mm hexagonal drive.

	AC 40 - 10700010 (G 35-25) € 24,00		AC 44 - 10700320 (U 90) € 45,00
	AC 41 - 10700310 (U 25) € 36,00		AC 46 - 10700430 (K 30E) € 34,00
	AC 42 - 10700030 (G 57-27) € 37,00		AC 47 - 10700510 (S 63) € 56,00
	AC 43 - 10700210 (SC 22) € 30,00		AC 48 - 10700440 (G90-58) € 39,00



	Hz								
mm		bar		mm	l/sec.	kg	dB(A)	dB(A)	m/sec ²
Hex 19	20.000	6,2	1/4" BSPT	10	1,9	1,22	88±3	98±3	10,9





SOLLEVATORI

Jacks

MADE IN ITALY



MOD. 1132

Cod. 16601132

€ 850,00

Sollevatore pneumatico costruito con membrana ad alta resistenza. Dotato di guida telescopica interna, dispositivo d'arresto a fine corsa e valvola di sicurezza.
Portata: 2 ton - Peso: 12 kg.

Pneumatic jack built with high resistant diaphragm. Equipped with internal telescopic guide, limit stop device and safety valve.
Capacity: 2 ton - Weight: 12 kg.

**Mod. PL 50**Cod. 16610050 - 50 mm **€ 80,00****Mod. PL 100**Cod. 16610100 - 100 mm **€ 90,00**

Prolunghe a richiesta per sollevatori pneumatici.
Optional extensions for pneumatic jacks.

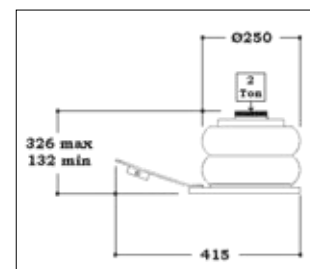
**MOD. 1203**

Cod. 16601203

€ 1.100,00

Sollevatore pneumatico costruito con membrana ad alta resistenza. Dotato di guida telescopica interna, dispositivo d'arresto a fine corsa e valvola di sicurezza.
Portata: 2 ton - Peso: 14 kg.

Pneumatic jack built with high resistant diaphragm. Equipped with internal telescopic guide, limit stop device and safety valve.
Capacity: 2 ton - Weight: 14 kg.

**Mod. PL 50**Cod. 16610050 - 50 mm **€ 80,00****Mod. PL 100**Cod. 16610100 - 100 mm **€ 90,00**

Prolunghe a richiesta per sollevatori pneumatici.
Optional extensions for pneumatic jacks.

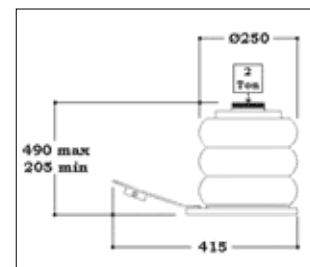
**MOD. 3214**

Cod. 16603214

€ 2.400,00

Sollevatore oleopneumatico portatile, il più leggero e compatto della gamma. Ideale da tenere a bordo del mezzo e per chi svolge assistenza su strada. Fornito in valigia in ABS per il trasporto.
Portata: 20/10 ton. Peso: 15 kg.
Consumo aria medio: 6,6 l/sec.

Portable air hydraulic jack, the lightest and most compact jack of the range. Ideal for keeping on board the vehicle and for people providing road assistance. With ABS case for transportation.
Capacity: 20/10 ton. Weight: 15 kg.
Average air consumption: 6,6 l/sec.

**Mod. 116**

Cod. 16610116 - 70 mm

€ 70,00**Mod. 117**

Cod. 16610117 - 120 mm

€ 80,00

Prolunghe in dotazione col sollevatore.
Extensions supplied with the jack.

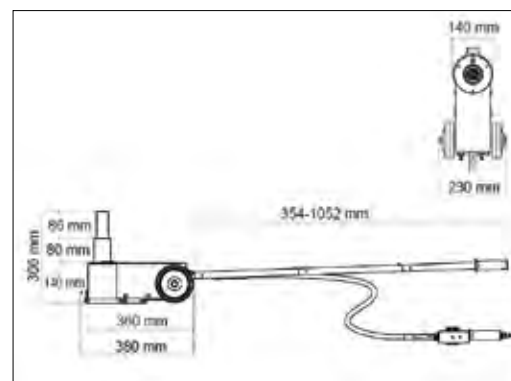

JACKS

MOD. 3217

Cod. 16603217

€ 2.300,00



Sollevatore oleopneumatico portatile, leggero e maneggevole, con manico smontabile, adatto per mezzi pesanti. Rientro automatico dei pistoni. Le due valvole di discesa garantiscono una tenuta perfetta in ogni situazione e una velocità controllata sotto carico. Ideale da tenere a bordo del mezzo e per chi svolge assistenza su strada.
Portata: 40/20 ton. Peso: 37 kg.
Consumo aria medio: 6,6 l/sec.

Lightweight and easy to handle portable air hydraulic jack, with removable handle, suitable for heavy vehicles. The pistons move back automatically. The two descent valves guarantee perfect holding in all situations and controlled speed under load. Ideal for keeping on board the vehicle and for people providing road assistance.
Capacity: 40/20 ton. Weight: 37 kg.
Average air consumption: 6,6 l/sec.



Mod. 116

Cod. 16610116 - 70 mm € 70,00

Mod. 117

Cod. 16610117 - 120 mm € 80,00

Prolunghe in dotazione col sollevatore.
Extensions supplied with the jack.

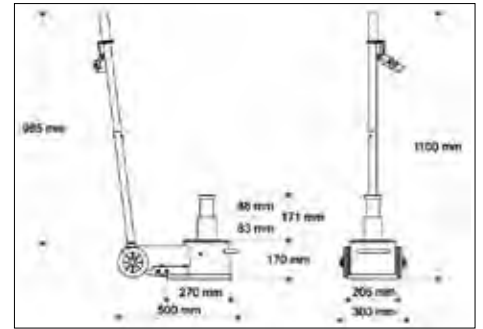

MOD. 1215

Cod. 16601215

€ 2.500,00



Sollevatore oleopneumatico per tutti i tipi di mezzi pesanti. Rientro del pistone automatico e doppia valvola di discesa che consente una velocità costante e controllata sotto carico e di aumentarla a vuoto.
Portata: 40/20 ton. Peso: 39 kg.
Consumo aria medio: 6,6 l/sec.

Air hydraulic jack for all types of heavy vehicles. Automatically moving back of the piston. Dual descent valve which provides a constant and controlled speed under load that can be increased with no load.
Capacity: 40/20 ton.
Weight: 39 kg. Average air consumption: 6,6 l/sec.



Mod. 116

Cod. 16610116 - 70 mm € 70,00

Mod. 117

Cod. 16610117 - 120 mm € 80,00

Prolunghe in dotazione col sollevatore.
Extensions supplied with the jack.

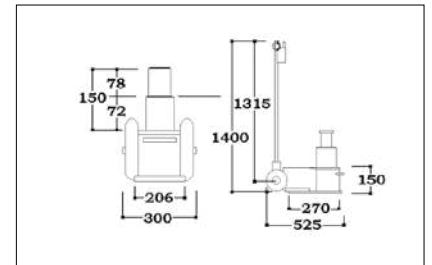

MOD. 1217

Cod. 16601217

€ 2.500,00



Sollevatore oleopneumatico per tutti i tipi di mezzi pesanti. Rientro del pistone automatico e doppia valvola di discesa che consente una velocità costante e controllata sotto carico e di aumentarla a vuoto.
Portata: 40/20 ton. Peso: 41 kg.
Consumo aria medio: 6,6 l/sec.

Air hydraulic jack for all types of heavy vehicles. Automatically moving back of the piston. Dual descent valve which provides a constant and controlled speed under load that can be increased with no load.
Capacity: 40/20 ton. Weight: 41 kg.
Average air consumption: 6,6 l/sec.



Mod. 116

Cod. 16610116 - 70 mm € 70,00

Mod. 117

Cod. 16610117 - 120 mm € 80,00

Prolunghe in dotazione col sollevatore.
Extensions supplied with the jack.

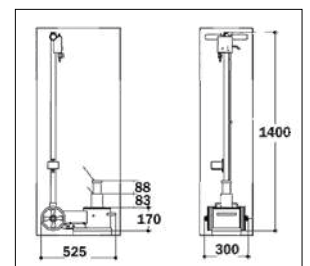

MOD. 1222

Cod. 16601222

€ 3.600,00

Sollevatore oleopneumatico per tutti i tipi di mezzi pesanti. Rientro del pistone automatico e doppia valvola di discesa che consente una velocità costante e controllata sotto carico e di aumentarla a vuoto.

Portata: 60/30 ton. Peso: 71 kg.
Consumo aria medio: 10 l/sec.

Air hydraulic jack for all types of heavy vehicles. Automatically moving back of the piston. Dual descent valve which provides a constant and controlled speed under load that can be increased with no load.

Capacity: 60/30 ton. Weight: 71 kg.
Average air consumption: 10 l/sec.

**Mod. 116**Cod. 16610116 - 70 mm **€ 70,00****Mod. 117**Cod. 16610117 - 120 mm **€ 80,00**

Prolunghe in dotazione col sollevatore.
Extensions supplied with the jack.

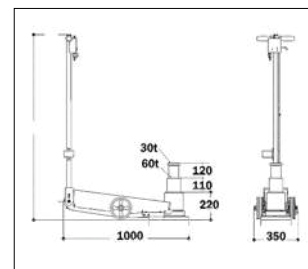
**MOD. 1135**

Cod. 16601135

€ 3.300,00

Sollevatore oleopneumatico per mezzi agricoli e macchine movimento terra. Rientro del pistone automatico e doppia valvola di discesa che consente una velocità costante e controllata sotto carico e di aumentarla a vuoto.

Portata: 30 ton. Peso: 57 kg.
Consumo aria medio: 6,6 l/sec.

Air hydraulic jack for agricultural and earth moving machines. Automatically moving back of the piston. Dual descent valve which provides a constant and controlled speed under load that can be increased with no load.

Capacity: 30 ton. Weight: 57 kg.
Average air consumption: 6,6 l/sec.

**Mod. 116**Cod. 16610116 - 70 mm **€ 70,00****Mod. 117**Cod. 16610117 - 120 mm **€ 80,00**

Prolunghe in dotazione col sollevatore.
Extensions supplied with the jack.

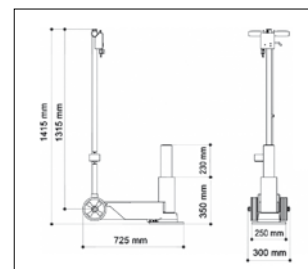
**MOD. 1312**

Cod. 16601312

€ 3.700,00

Sollevatore oleopneumatico per tutti i tipi di mezzi pesanti. Rientro del pistone automatico e doppia valvola di discesa che consente una velocità costante e controllata sotto carico e di aumentarla a vuoto.

Portata: 60/30/15 ton. Peso: 50 kg.
Consumo aria medio: 10 l/sec.

Air hydraulic jack for all types of heavy vehicles. Automatically moving back of the piston. Dual descent valve which provides a constant and controlled speed under load that can be increased with no load.

Capacity: 60/30/15 ton - Weight: 50 kg.
Average air consumption: 10 l/sec.

**Mod. 116**Cod. 16610116 - 70 mm **€ 70,00****Mod. 117**Cod. 16610117 - 120 mm **€ 80,00**

Prolunghe in dotazione col sollevatore.
Extensions supplied with the jack.

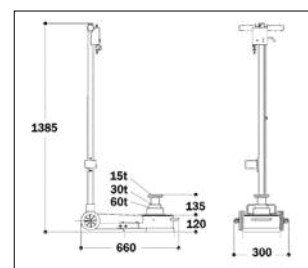

JACKS

MOD. 1315

Cod. 16601315

€ 3.800,00



Sollevatore oleopneumatico per mezzi pesanti che utilizzano sospensioni pneumatiche molto vicine alla ruota o pneumatici ribassati.
Portata: 60/30/18 ton. Peso: 46 kg.
Consumo aria medio: 6,6 l/sec.

Air hydraulic jack made for use with heavy vehicles fitting lowered tyres or pneumatic suspensions very close to the wheel.
Capacity: 60/30/18 ton. Weight: 46 kg.
Average air consumption: 6,6 l/sec.



Mod. 116
Cod. 16610116 - 70 mm € 70,00

Mod. 117
Cod. 16610117 - 120 mm € 80,00

Prolunghe in dotazione col sollevatore.
Extensions supplied with the jack.

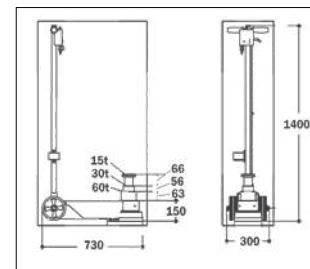

Utilizzo consigliato

Recommended use

	1132	1135	1203	1215	1217	1222	1312	1315	3214	3217
	●		●							
	●		●							
	●		●							
	●		●							
	●		●							
	●		●							
				●	●	●		●	●	●
						●				
						●				
				●	●	●		●	●	●
				●	●	●		●	●	●
				●	●	●		●	●	●
				●	●	●		●	●	●
		●				●				
		●								
		●				●				
		●				●				
		●				●				
		●				●				
							●	●		
							●	●		
							●	●		





KIT & ACCESSORI

Kits & accessories



Cod. 500009

€ 270,00

Cassetta utensili professionali 155 pz da 1/4", 3/8" e 1/2". Confezione 2 pz.
155 pcs professional 1/4", 3/8" & 1/2" socket set. 2 pcs per pack.



Cricchetti estensibili Extendable ratchet handles	1/4" x 72T - 3/8" x 72T - 1/2" x 72T
Prolunghe Extensions	1/4" x 2" - 1/4" x 4" - 3/8" x 3" - 3/8" x 6" - 1/2" x 5" - 1/2" x 10"
Chiavi a brugola Hexagonal keys	1,25-1,5-2-2,5-3 mm
Snodi Universal Joints	1/4"-3/8"-1/2"
Bussole per candela Spark plug sockets	3/8" x 16 mm - 1/2" x 16 mm - 1/2" x 21 mm
Cacciavite portainseriti Spinner handle	1/4"
Bussole portainseriti Bits holders	3/8" x 10 mm - 1/2" x 10 mm
Bussole Sockets	1/4" x 4-4,5-5-5,5-6-7-8-9-10-11-12-13-14 mm 3/8" x 10-11-12-13-14-15-16-17-18-19 mm 1/2" x 10-11-12-13-14-15-16-17-18-19-20-21-22-24-27-30-32 mm
Bussole lunghe Deep sockets	1/4" x 4-5-6-7-8-9-10 mm 3/8" x 10-11-12-13-14-15 mm 1/2" x 14-15-17-19-22 mm
Bussole Torx Star sockets	1/4" x E4-E5-E6-E7-E8 3/8" x E10-E12-E14-E16-E18 1/2" x E20-E22-E24
Inseriti 10 mm x 30L Bits 10 mm x 30L	Tampered star: TH20-TH25-TH30-TH40-TH45-TH50-TH55 Spline: M5-M6-M8-M10-M12 Hex: 4-5-6-7-8-10-12 mm Phillips: 2-3
Inseriti bussola Bit sockets:	<ul style="list-style-type: none"> ● 1/4" x 3-4-5-6-7 mm ● 3/8" x 6-7-8-9-10 mm ○ 1/4" x 3-4-4,5-5-5,5-6-6,5-7 mm ⊕ 1/4" x T8-T9-T10-T15-T20-T25-T27-T30-T40 ⊕ 3/8" x T45-T47-T50-T55-T60 ⊕ 1/4" x 0-1-2-3 ⊕ 1/4" x 0-1-2-3

KITS & ACCESSORIES

Cod. 500004

€ 54,00

Cassetta utensili professionali 46 pz da 1/4". Confezione 5 pz.
46 pcs professional 1/4" socket set. 5 pcs per pack.

Cricchetto	Ratchet handle	1/4" x 72T
Prolunghe	Extensions	1/4" x 50 mm - 1/4" x 100 mm
Barra scorrevole T	Sliding T-Bar	1/4" x 115 mm
Cacciavite portainseri	Spinner handle	1/4" x 6"
Prolunga flessibile	Flex extension	1/4" x 6"
Snodo	Universal Joint	1/4"
Adattatore	Socket adaptor	1/4"
Chiavi a brugola	Hexagonal keys	1,25-1,5-2-2,5 mm
Bussole	Sockets	1/4" x 4-4,5-5-5,5-6-7-8-9-10-11-12-13-14 mm

Inserti	Bit sockets	<ul style="list-style-type: none"> ● 3-4-5-6-7 mm ○ 4-5-5-7 mm ⊕ T10-T15-T20-T25-T27-T30-T40 ⊕ 1-2-3 ⊕ 1-2-3
---------	-------------	-----------------------------------------------------------------------------------------------------------------------------------------------------------------



Cod. 500018

€ 100,00

Cassetta utensili professionali 23 pz da 1/2". Confezione 5 pz.
23 pcs professional 1/2" socket set. 5 pcs per pack.

Cricchetto	Ratchet handle	1/2" x 72T
Bussole	Sockets	1/2" x 10-11-12-13-14-15-16-17-18-19-20-21-22-23-24-27-30-32 mm
Prolunghe	Extensions	1/2" x 125 mm - 1/2" x 250 mm
Snodo	Universal Joint	1/2"
Adattatore scorrevole	Sliding adaptor	1/2" M x 3/8" F



Cod. 500100

€ 50,00

8in1 Ratchet Wrench

Chiave a cricchetto reversibile a 90 denti in Cromo Vanadio, con funzione 8 in 1. Con un unico utensile, possibilità di serrare 8, 10, 12, 13, 14, 15, 17 e 19 mm.

90T 8 in 1 Chrome-Vanadium reversible wrench. With a single tool, it is possible to tighten 8, 10, 12, 13, 14, 15, 17 and 19 mm.

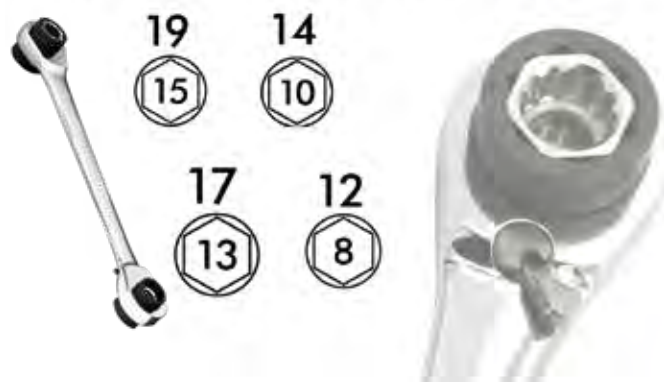

Cod. 500005

Cricchetto 72 denti **estensibile** 1/4".
1/4" **extendable** 72T ratchet handle.

€ 32,00



Cod. 500006

Cricchetto 72 denti **estensibile** 3/8".
3/8" **extendable** 72T ratchet handle.

€ 36,00



Cod. 500007

Cricchetto 72 denti **estensibile** 1/2".
1/2" **extendable** 72T ratchet handle.

€ 44,00

**Spirali in poliuretano**

Il poliuretano offre i seguenti vantaggi:

- elevata memoria elastica
- insensibile agli schiacciamenti
- resistenza ad oli e grasso
- ingombro ridotto

Polyurethane re-coil hoses

The polyurethane has the following advantages:

- it keeps its shape
- it is not sensitive to the deflections
- it is resistant to oils and grease
- reduced dimensions

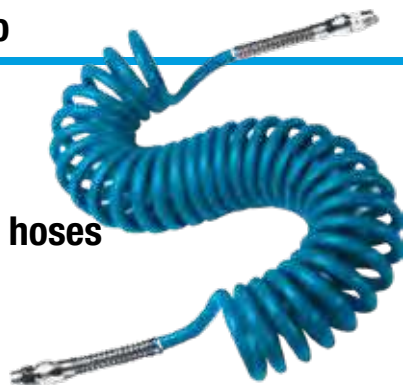

Cod.	Ø In x out	Sviluppo Length	Attacco maschio girevole Male swivel connector	€
17040551	5,5 x 8 mm	5 m	1/4" BSPT	33,00
17040552	5,5 x 8 mm	7,5 m	1/4" BSPT	37,00
17040553	5,5 x 8 mm	10 m	1/4" BSPT	43,00
17040651	6,5 x 10 mm	5 m	1/4" BSPT	39,00
17040652	6,5 x 10 mm	7,5 m	1/4" BSPT	49,00
17040653	6,5 x 10 mm	10 m	1/4" BSPT	58,00
17040803	8 x 12 mm	10 m	3/8" BSPT	64,00
17040804	8 x 12 mm	15 m	3/8" BSPT	84,00

KITS & ACCESSORIES



Cod. 19200610

€ 18,00

Pistola soffiaggio professionale con silenziatore. Corpo in nylon, boccola in ottone, tubo metallico e molle interne in acciaio inox.

Professional silenced air blow gun. Body in nylon, inlet connection thread in brass, metal pipe and inner spring in stainless steel.



Cod. 19200630

€ 22,00

Pistola soffiaggio professionale con tubo 13 cm e silenziatore. Corpo in nylon, boccola in ottone, tubo metallico e molle interne in acciaio inox.

Professional air blow gun with 13 cm tube and silencer. Body in nylon, inlet connection thread in brass, metal pipe and inner spring in stainless steel.



Cod. 19200660

€ 40,00

Pistola soffiaggio professionale con silenziatore e **RIDUTTORE DI PRESSIONE** (3,5 bar). Corpo in nylon, boccola in ottone, tubo metallico e molle interne in acciaio inox.

Professional **PRESSURE REDUCER** (3,5 bar) silenced air blow gun. Body in nylon, inlet connection thread in brass, metal pipe and inner spring in stainless steel.



Cod. 19200120

€ 16,00

Pistola soffiaggio "PRO" (con boccola filettata in ottone).

Blowing gun "PRO" type (with threaded brass bushing).



Cod. 19200150

€ 37,00

Pistola soffiaggio "PRO" 48 cm.

48 cm blowing gun "PRO" type.



Cod. 19200340

€ 150,00

Espositore da banco, composto da 10 pistole "PRO".

Counter display stand, complete with 10 "PRO" guns.

Bilanciatori con cavo in nylon

Balancers with nylon cable

Struttura in materiale sintetico. Molle d'acciaio extra. Dispositivo per la regolazione del carico della molla con comando esterno.

ABS housing. Steel springs. Outside spring adjustment.

Mod.	Cod.	Kg	Corsa cavo Cable length	€
AC 30	17100015	0,5 - 1,5	1600 mm	54,00
AC 31	17100030	1,5 - 3,0	1600 mm	58,00

Bilanciatori con cavo in acciaio

Balancers with steel cable

Struttura in materiale sintetico. Molle d'acciaio extra. Dispositivo per la regolazione del carico della molla con comando esterno.

ABS housing. Steel springs. Outside spring adjustment.

Mod.	Cod.	Kg	Corsa cavo Cable length	€
AC 32	17100070	3,0 - 6,0	1600 mm	147,00
AC 33	17100100	5,0 - 10,0	1600 mm	165,00
AC 34	17100180	13,0 - 19,0	1600 mm	310,00

MADE IN ITALY



MADE IN ITALY



MOD. AC 12

Cod. 10900151

€ 16,00 cad.

MADE IN ITALY



Barattolo olio speciale per utensili pneumatici, sbloccante e antiossidante.
Confezione da 15 pezzi.

Oil for pneumatic tools (15 pcs box).

MOD. AC 12/5

Cod. 10900155

€ 72,00

MADE IN ITALY



Tanica 5 l olio speciale per utensili pneumatici.
Confezione da 4 pezzi.

5 l plastic container of special oil for pneumatic tools (4 pcs box).

KITS & ACCESSORIES



MOD. AC 7

Cod. 10700750

€ 26,00

Tubo silenziatore per mod. 378 - 380 - 383 - 394 - 478 - 495 - 496 - 606 - 620 - 621.

Silenced exhaust hose assembly for mod. 378 - 380 - 383 - 394 - 478 - 495 - 496 - 606 - 620 - 621.



MOD. AC 16

Cod. 17200011

€ 11,00

Miniolatore per utensili pneumatici con attacco da 1/4".

1/4" Mini oiler for pneumatic tools.



MOD. AC 17/6

Cod. 10701060

€ 20,00

Fresa Ø 6 mm.

Ø 6 mm milling cutter.



MOD. AC 17/8

Cod. 10701080

€ 20,00

Fresa Ø 8 mm.

Ø 8 mm milling cutter.



MOD. AC 62

Cod. 17211411

€ 15,00

Regolatore aria 1/4".

1/4" air regulator.



Cod. 503612

€ 9,00

Pistola di soffiaggio.

Blowing gun.



Cod. 503615

€ 10,00

Pistola di soffiaggio canna lunga.

Blowing gun with long nozzle.



Cod. 503621

€ 25,00

Pistola gonfiaggio con manometro.

Inflating gun with pressure gauge.





DISTRIBUTORE PER L'ITALIA

PEGASO 
E Y E W E A R

OCCHIALI

Glasses





LEGENDA LEGEND



Antigraffio
Anti-scratch



Resistenza al metallo fuso e ai solidi caldi
Fused Metals and Hot Solids Resistant



Materiale antiscivolo per
adattamento al casco
Antislip material for helmet
adaptation



Anti appannamento
Antifog



Compatibile con occhiali graduati
Compatible with graduated glasses



Aste regolabili
Adjustable rods



Resistenza alle gocce di
liquido
Resistance against drops
of liquids



Resistenza ai particolati > 5 micras
Thick Dust Resistant > 5 micras



Filtro UV
UV filter

WORK&FUN Cod. 750125 PACK

€ 380,00

Espositore occhiali graduati Work&Fun, certificati per il lavoro, composto da 2 occhiali per diottria per la vendita e un occhiale per diottria per prova.

Work&Fun certified graduated glasses display unit composed by 2 glasses per diopter for sales and one per diopter for test.



+1.0

Cod. 7512519010

€ 38,00



+1.5

Cod. 7512509015

€ 38,00



+2.0

Cod. 7512569020

€ 38,00



+2.5

Cod. 7512539025

€ 38,00



+3.0

Cod. 7512589030

€ 38,00

GLASSES



LITE Cod. 7500000020



€ 15,00



XL21 Cod. 750000XL21



€ 20,00



EOS Cod. 7500000022



€ 21,00



IMAX Cod. 7500015601



€ 21,00

**BLACK&WHITE** Cod. 7500010301**€ 13,00****BLACK&WHITE** Cod. 7500010303**€ 20,00****BASIC 3** Cod. 7500000409**€ 8,50****BASIC 7** Cod. 7500000439**€ 8,50****SICURIS** Cod. 7500000739**€ 8,50**

GLASSES



VOLTA Cod. 7501279900

€ 13,00



EXTREME F-1 Cod. 7590081005

€ 23,00



FOTOCROM Cod. 7512199030

€ 42,00



SI ADATTA AI CAMBIAMENTI DELLA LUCE
ADJUSTS ITSELF TO LIGHT CHANGES



BLACK&WHITE Cod. 7500010302

€ 13,00



POLARIZZATO - POLARIZED



STREET Cod. 7512699530

€ 45,00



Indice alfanumerico

Alphanumeric index

Mod. / Cod.	Pag.
UTENSILI TOOLS	
AT10 / 2	25
200	88
203	89
205	89
210	90
211	91
212	91
222	90
236	74
237	74
250	58
252	58
255	58
260	60
262	60
265	60
270	59
272	59
275	59
301	13
310	13
315	16
315/K	16
320	20
333	18
352	14
355	16
357	19
357 LL	19
358	21
358 LL	21
359D	23
359D LL	23
372	14
375	48
380	48
383	51
401	37
402	36
403	37
410	100
412	101
413	100
414	101
415	66
416	64
417	64
420	83
421	83
423	67
424	67
425	67
427	85
435	65
441	38
441/K	38
442	36
453	17
453/K	17
457	17
458	15
462	18
462/K	18
466	20
472	39
474	83

Mod. / Cod.	Pag.
475	84
478/A	49
479	88
480	38
482	39
482/K	39
484	61
485	61
487	62
489	62
490/P	12
491/P	12
492/A	51
493	50
495/A	49
495/F	61
496	50
500	33
505	33
506	33
520	65
525	66
526	84
527	84
530	75
532	76
532 L	78
533	80
533/25	80
533 B	80
533/25 B	80
533 L	79
534	82
540	71
543	70
545	71
550	104
553	94
554	94
557/K	95
559/S	95
562	105
565	96
567	97
568	97
571	96
580	12
590	54
591	55
603	44
605	45
606	44
608	45
609	45
610	43
611	43
620	44
630	42
632	42
700	63
710	63
715	63
750	75
752	77
753	81
814D	24
814DLL	24

Mod. / Cod.	Pag.
815	22
815 P.	22
815LL	22
815LL P.	22
900	104
1132	108
1135	110
1203	108
1215	109
1217	109
1222	110
1312	110
1315	111
3214	108
3217	109
ACCESSORI ACCESSORIES	
AC 7	119
AC 8	58
AC 9	88
AC 11	88
AC 12	118
AC 12/5	118
AC 16	119
AC 17/6	119
AC 17/8	119
AC 18	61
AC 19	67
AC 19/1	67
AC 19/2	67
AC 19/3	67
AC 19/4	67
AC 19/5	67
AC 19/6	67
AC 19/7	67
AC 20	94
AC 21	94
AC 22	94
AC 30	118
AC 31	118
AC 32	118
AC 33	118
AC 34	118
AC 40	105
AC 41	105
AC 42	105
AC 43	105
AC 44	105
AC 46	105
AC 47	105
AC 48	105
AC 50/1	71
AC 50/2	71
AC 60	119
AC 62	119
AC 70	62
AC 71	62
AC 72	62
AC 73	62
AC 74	62
AC 77	74
AC 78	74
AC 78/1	75
AC 82/1	51
AC 90	76
AC 90/15	79
AC 91	76
AC 92	76

Mod. / Cod.	Pag.
AC 93	76
AC 95	83
AC 96	83
AC 96/14	83
AC 100/1	48
AC 119	67
AC 119/1	67
AC 119/2	67
AC 120	67
AC 120/1	67
AC 120/2	67
AC 200	88
AC 205/1	89
AC 205/2	89
AC 205/3	89
AC 210	90
AC 212	91
AC 222/1	90
AC 222/2	90
AC 222/3	90
AC 236/1	74
AC 236/2	74
AC 236/3	74
AC 237/21	74
AC 237/22	74
AC 237/23	74
AC 237/31	74
AC 237/32	74
AC 237/33	74
AC 427/1	85
AC 427/2	85
AC 427/3	85
AC 427/4	85
AC 427/5	85
AC 427/6	85
AC 427/7	85
AC 427/8	85
AC 427/9	85
AC 427/10	85
AC 427/11	85
AC 458	15
AC 458/R	15
AC 543	70
AC 545/1	71
AC 545/2	71
AC 545/3	71
AC 545/4	71
AC 557/1	95
AC 557/2	95
AC 557/3	95
AC 557/4	95
AC 557/5	95
AC 559/1	95
AC 559/2	95
AC 559/3	95
AC 565/1	96
AC 565/2	96
AC 565/3	96
AC 565/4	96
AC 590/1	54
AC 590/2	54
AC 590/3	54
AC 590/4	54
AC 590/5	54
AC 590/6	54
AC 590/7	54
AC 590/8	54

Mod. / Cod.	Pag.
AC 590/9	54
AC 590/10	54
AC 590/11	54
AC 590/12	54
AC 590/13	55
AC 590/14	55
AC 590/15	55
AC 590/16	55
AC 590/17	55
AC 590/18	55
AC 590/19	55
500004	115
500005	116
500006	116
500007	116
500009	114
500018	115
500100	116
503612	119
503615	119
503621	119
10600179	88
10600279	88
10600379	88
10600579	88
10600679	88
10702011	61
10702012	61
10702041	74
10702042	74
10802010	29
10802011	29
10802012	29
10802013	29
10802014	29
10802015	29
10802016	29
10802017	29
10802018	29
10802019	29
10802020	29
10802021	29
10802022	29
10802023	29
10802024	29
10802025	29
10802026	29
10802027	29
10802030	29
10802032	29
10803013	29
10803016	29
10803017	29
10803018	29
10803019	29
10803021	29
10803022	29
10803024	29
10803027	29
10803030	29
10804017	31
10804019	31
10804021	31
10804022	31
10804023	31
10804024	31
10804025	31

Mod. / Cod.	Pag.
10804026	31
10804027	31
10804028	31
10804030	31
10804032	31
10804033	31
10804034	31
10804036	31
10804038	31
10804041	31
10804046	31
10805019	31
10805022	31
10805024	31
10805027	31
10805028	31
10805030	31
10805032	31
10805033	31
10805034	31
10805036	31
10806024	32
10806027	32
10806030	32
10806032	32
10806033	32
10806036	32
10806038	32
10806039	32
10806041	32
10806046	32
10806050	32
10806055	32
10806060	32
10806065	32
10806070	32
10807024	32
10807027	32
10807030	32
10807032	32
10807033	32
10807036	32
10807038	32
10807039	32
10807041	32
10807046	32
10807050	32
10807055	32
10807060	32
10808050	33
10808055	33
10808060	33
10808065	33
10808070	33
10808075	33
10808080	33
10808085	33
10808090	33
10808095	33
10808100	33
10808105	33
10808110	33
10808115	33
10813017	29
10813019	29
10813021	29
10813022	29

Mod. / Cod.	Pag.
10814015	29
10814017	29
10814019	29
10815024	31
10815027	31
10815030	31
10817027	32
10817030	32
10817032	32
10820002	30
10820004	31
10820006	32
10820008	33
10830204	30
10830206	30
10830404	31
10830604	32
10830606	32
10840024	30
10840042	31
10840046	31
10840064	32
10840086	33
10850010	30
10850011	30
10850012	30
10850014	30
10850016	30
10850018	30
10850020	30
10850022	30
10850024	30
10851030	30
10851040	30
10851045	30
10851050	30
10851055	30
10851060	30
10852008	30
10852010	30
10852012	30
10852014	30
10852017	30
10852019	30
16610050	108
16610100	108
16610116	108
16610117	108
17040551	116
17040552	116
17040553	116
17040651	116
17040652	116
17040653	116
17040803	116
17040804	116
17970017	29
17970019	29
17970021	29
17970022	29
19200120	117
19200150	117
19200340	117
19200610	117
19200630	117
19200660	117
1070063201	75

Mod. / Cod.	Pag.
1070211001	79
1070211002	76
OCCHIALI	GLASSES
750000XL21	123
7500000020	123
7500000022	123
7500000409	124
7500000439	124
7500000739	124
7500010301	124
7500010302	125
7500010303	124
7500015601	123
750125PACK	122
7501279900	125
7512199030	125
7512509015	122
7512519010	122
7512539025	122
7512569020	122
7512589030	122
7512699530	125
7590081005	125

GARANZIA

warranty

GARANZIA DEL FABBRICANTE

L'Airtec srl garantisce che i suoi prodotti saranno esenti da difetti di materiale e di fabbricazione per 12 mesi a decorrere dalla data di acquisto. La garanzia è valida per i prodotti acquistati nuovi presso l'Airtec srl o i rivenditori autorizzati. Questa garanzia non è valida se i prodotti sono stati usati in modo improprio, manomessi o riparati da persone non autorizzate dall'Airtec srl stessa. Nel caso in cui uno dei prodotti Airtec srl presenti difetti di materiale o di fabbricazione entro 12 mesi dalla data di acquisto, recapitarlo, previa autorizzazione scritta, al Centro assistenza Airtec presso la sede dell'azienda con trasporto a cura di Airtec srl, la quale riparerà o sostituirà gratuitamente, a propria discrezione, i prodotti difettosi senza alcuna spesa da parte dell'acquirente. Qualora, in fase di riparazione, venissero riscontrati elementi che rendessero la garanzia inapplicabile, verrà prodotto un preventivo di riparazione (comprensivo dei costi di gestione), con riserva di accettazione da parte dell'acquirente.

Norme di sicurezza

safety instructions

NORME DI SICUREZZA PER AVVITATORI E UTENSILI PNEUMATICI

Lo scopo di AIRTEC è di offrirvi utensili che permettano di svolgere un efficiente lavoro di sicurezza. Il più importante dispositivo di sicurezza per questo o qualsiasi altro utensile siete Voi. La Vostra attenzione e un buon criterio di giudizio sono la migliore protezione da eventuali incidenti. Tutti i rischi non possono essere qui elencati, ma abbiamo cercato di metterne in evidenza alcuni dei più importanti. Per ulteriori informazioni circa la sicurezza, consultare:

- Eventuali altri documenti imballati con l'utensile.
- Il Vs. datore di lavoro, enti locali o il Consiglio della Comunità Europea.
- "Requisiti di sicurezza per utensili manuali non utilizzando energia elettrica" disponibile presso: Comitato Europeo per la Normalizzazione, rue de Stassart 36, 1050 Bruxelles, Belgio.

RISCHI DOVUTI AL COLLEGAMENTO DELL'ARIA

Gli impianti di aria compressa possono essere fonte di gravi danni. Disinserire l'aria dagli utensili quando questi non sono in funzione, prima di cambiare gli accessori o quando si effettuano manutenzione e riparazione. Non direzionare mai l'aria verso se stessi o gli altri. Colpi di frusta di tubi, accidentalmente scollegati, possono causare seri danni. Controllare sempre se tubi o raccordi sono danneggiati o allentati. Non utilizzare raccordi rapidi sugli utensili. Consultare lo schema allegato per un corretto impianto. Non superare la pressione di massimo utilizzo raccomandata (6,2 bar).

RISCHI DI IMPIGLIAMENTO

Tenere una distanza di sicurezza dalle parti in rotazione degli utensili. Non indossare collane, bracciali o vestiti lenti. Prestare attenzione al tipo di abbigliamento in modo da evitare che possa impigliarsi in parti in movimento degli utensili. Prestare attenzione ai capelli lunghi. Evitare il contatto diretto con accessori durante e dopo l'uso. I guanti ridurranno il rischio di tagli e bruciature. Utilizzare sempre accessori appropriati.

RISCHI DA PARTI PROIETTATE

Anche le piccole schegge possono danneggiare gli occhi e provocare cecità. Indossare sempre protezione per gli occhi e il viso quando si lavora con gli utensili, quando se ne effettua la manutenzione o si cambiano gli accessori. Assicurarsi che tutti gli altri lavoratori nelle vicinanze stiano indossando protezioni per gli occhi.

RISCHI RELATIVI AL LUOGO DI LAVORO

Scivolare, incespicare, cadere sono le cause maggiori di lesioni anche serie. Prestare attenzione a tubazioni eccessivamente lunghe lasciate a terra o sul posto di lavoro. Mantenere una posizione del corpo bilanciata ed assicurarsi un appoggio solido. Movimenti ripetitivi, posizioni scomode e l'esposizione a vibrazioni possono essere dannose per mani e braccia. Elevati livelli di rumorosità possono causare la perdita permanente dell'udito. Utilizzare protezioni per l'udito. Evitare di inspirare polvere o di maneggiare scorie di lavoro che possono essere dannose per la Vostra salute. Prestare attenzione a eventuali rischi dovuti al Vostro lavoro.

ULTERIORI INFORMAZIONI DI SICUREZZA

Gli operatori e il personale addetto alla manutenzione devono essere fisicamente idonei a maneggiare le dimensioni, il peso e la potenza degli utensili. Questi utensili e i loro accessori non devono essere modificati. Questi utensili non sono isolati per venire a contatto con fonti di energia elettrica e non possono essere utilizzati in ambienti con atmosfera esplosiva.

WARRANTY

Airtec's products are warranted to be free from defects in material and workmanship for 12 months from the date of purchase. This warranty does not apply to products which have been abused, misused or modified. The defective products must be returned, transportation prepaid, with the agreement of Airtec and include adequate proof of the date of purchase. Airtec will, at its opinion, repair or replace defective products free of charge.

PNEUMATIC TOOLS SAFETY INSTRUCTIONS

The goal of Airtec is to produce tools that help You work safely and efficiently. Your care and good judgement are the best protection against injury. All possible hazards cannot be listed here. We try at least to highlight the most important ones. For additional safety information:

- Read the documents and information packed with the tool.
- Contact Your employer union and/or trade association.
- Read "Safety requirement for hand held non electric power tools" available at: European Committee for Standardization, rue de Stassart 36, 1050 Bruxelles, Belgium.

AIR SUPPLY AND CONNECTION HAZARDS

Compressed air lines pressure can cause serious injury. Always shut off air supply, drain hose of air pressure and disconnect tool from air supply when not in use, before changing accessories or when making repairs. Never direct air at Yourself or anyone else. Whipping hoses can cause serious injury. Always check for damaged or loose hoses and fittings. Do not use quick release fittings with tool. See instructions for correct set-up. Whenever universal twist couplings are used, lock pins must be installed. Do not exceed maximum air pressure of 6,2 bar.

ENTANGLEMENT HAZARDS

Keep away from rotating drive. Do not wear jewellery or loose clothing. Choking can occur if neckwear is not kept away from tool and accessories. Scalping can occur if hair is not kept away from tool and accessories. Avoid direct contact with accessories during and after use. Gloves will reduce the risk of cuts or burns. Use only proper accessory retainers.

PROJECTILE HAZARDS

Even small projectiles can injury eyes and cause blindness. Always wear impact resistant eye and face protection when involved with or near the operation, repair or maintenance of the tools or changing accessories on the tool. Be sure all others in the area are wearing impact resistant eye and face protection. Never operate the tool at idle. It may run too fast and cause the accessories to be thrown off the tool.

WORKPLACE HAZARDS

Slip/trip/fall is a major cause of serious injury or death. Beware of excess hose left on the walking or work surface. Maintain a balanced body position and secure footing. Repetitive work motions, awkward positions and exposure to vibration can be harmful to hands and arms. High sound levels can cause permanent hearing loss. Use hearing protection as recommended by Your employer or OSHA regulation. Avoid inhaling dust or handling debris from work process which can be harmful to Your health. Be aware of potential hazards created by Your work activity.

ADDITIONAL SAFETY TOPICS

Proceed with care in unfamiliar surroundings. Operator and maintenance personnel must be physically able to handle the bulk, weight and power of the tool. This tool and its accessories must not be modified. This tool is not isolated for coming into contact with electric power sources. This tool is not recommended for use in explosive atmospheres.

ISTRUZIONI

instructions

ISTRUZIONI INSTALLAZIONE E MANUTENZIONE

Vogliate attenerVi ai seguenti consigli allo scopo di ottenere un prolungato e corretto funzionamento dei Vs. utensili:

- Prima di mettere in funzione l'utensile, inserire alcune gocce d'olio fluido SAE 10-15 (AIRTEC AC 12) tramite l'attacco dell'aria.
- Fare uscire aria dal tubo d'alimentazione prima di collegarlo alla macchina (utensile) per verificare che l'aria d'alimentazione sia asciutta e pulita.
- Consigliamo l'utilizzo d'un gruppo filtro-lubrificatore o per lo meno di un oliatore di linea appropriato.
- A 6,2 bar si raggiungono le potenze indicate nelle varie tabelle. Per corretti manutenzione e funzionamento degli utensili, vogliate eseguire i seguenti controlli:
 - a) Ogni 2/3 ore di lavoro, lubrificare con alcune gocce d'olio SAE 10-15 (AIRTEC AC 12) gli utensili sprovvisti di lubrificazione.
 - b) Ogni 8 ore, riempire l'oliatore di linea nelle macchine che ne siano corredate.
 - c) Ogni 60 ore, controllare la parte battente degli avvitatori ad impulsi e, in mancanza di grasso, provvedere ad aggiungere grasso al bisolfuro di molideno nella quantità indicata nel manuale di manutenzione.
 - d) Prima di lunghi periodi di fermo dell'utensile, effettuare una pulizia accurata ed ingrassare la macchina.
 - e) Dopo il periodo di fermo, introdurre nel tubo aria un poco di gasolio, tenendo il pulsante premuto. Fare funzionare la macchina per alcuni secondi, quindi lubrificare il motore.
 - f) La pressione all'entrata dell'utensile NON deve superare i 6,2 bar.
 - g) Per ottenere le prestazioni indicate, è molto importante utilizzare tubi aria dimensionati correttamente.

Per gli avvitatori ad impulsi vogliate notare che i valori di serraggio indicati nel catalogo spesso non possono essere ottenuti, dato che con l'utilizzo di guarnizioni, rondelle elastiche, etc. si hanno i cosiddetti FISSAGGI ELASTICI che disperdono buona parte della coppia di serraggio. Serraggi specifici dovranno essere controllati con apposita chiave dinamometrica. I valori di coppia da noi indicati vanno verificati su serraggi RIGIDI, ad una pressione di 6,2 bar.

Per quanto riguarda i termini di garanzia, noi decliniamo ogni responsabilità nei casi in cui non siano state rispettate le istruzioni per il corretto funzionamento, in cui gli utensili siano stati manomessi o riparati da persone non competenti o in cui vengano utilizzati ricambi non originali.

INSTRUCTIONS FOR SET UP AND MAINTENANCE

Please follow the suggestions listed hereafter to guarantee the best working conditions and a longer life for Your tools:

- Oil the tool before You connect it to the air supply. Use SAE 10-15 Oil (AIRTEC AC 12).
- Let air out the air line before connecting the tool to make sure the air is clean and dry.
- Use an air filter + lubricator set or at least an in-line lubricator.
- Set the air pressure at 6,2 bar to reach the torque values mentioned in the catalogues.

To get the correct performance of the tools check them at regular intervals:

- a) Every 2/3 hours oil the tools which are not fitted with in-line oiler (SAE 10-15 Oil – AIRTEC AC 12).
- b) Every 8 hours fill the in-line oiler.
- c) Every 60 hours please check the impact mechanism of impact wrenches. If the grease is missing, please add the quantity of bisulphide molybdenum grease shown in the maintenance manual.
- d) In case You store the tool for a long time clean it and grease it.
- e) Oil the tool before putting it in service again.
- f) The air pressure at the tool must not exceed 6,2 bar.
- g) To reach the torque values shown on the catalogue use the correct hose inside diameter.

Please note that the torque figures shown on the catalogue might not be reached due to the use of additional washers, springs, etc. which disperse the torque. Use a torque spanner in case a precise torque is required. The torque figures of our catalogue were reached on a fix joint at 6,2 bar.

As far as the warranty is concerned, we decline any responsibility when the tools have not been maintained properly, have been disassembled, have been repaired by unqualified persons or have been fixed with non original spares.

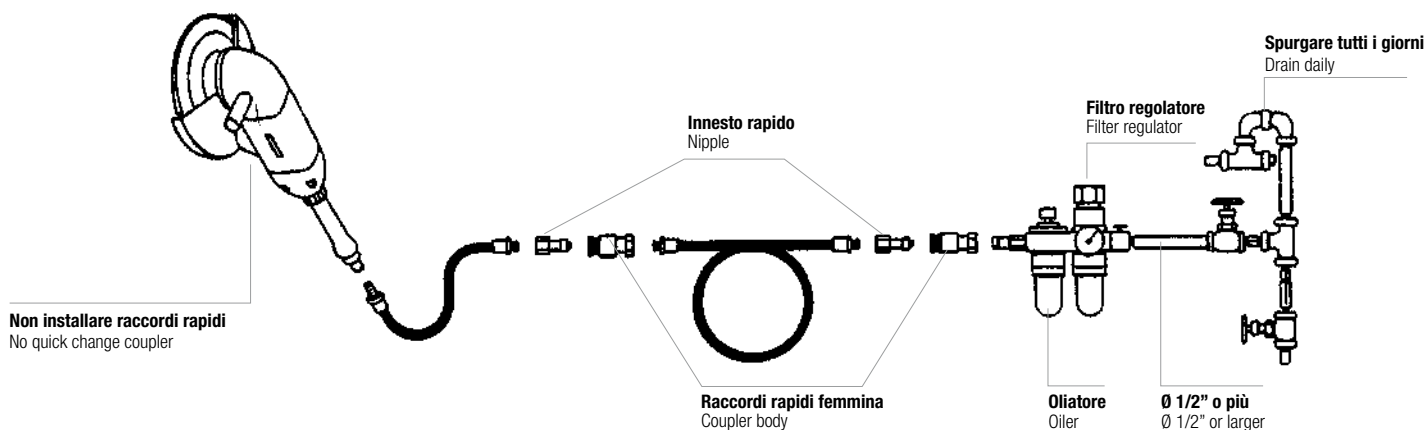





























Espositori display

AIRTEC



Legenda

legend

 <p>Dimensioni (mm) Dimensions (mm)</p>	 <p>Dimensione pinza Collet size</p>
 <p>Attacco quadro Square drive</p>	 <p>Attacco portautensile esagonale femmina Hex bit holder</p>
 <p>Capacità bullone Bolt capacity</p>	 <p>Capacità punta Drill bit size</p>
 <p>Velocità a vuoto - giri/min Free speed - rpm</p>	 <p>Attacco mandrino Chuck connection</p>
 <p>Coppia massima - avvitamento/svitamento Max torque - tighten/loosen</p>	 <p>Capacità vite Max screw capacity</p>
 <p>Campo di coppia Torque range</p>	 <p>Capacità disco Pad capacity</p>
 <p>Pressione aria raccomandata Air pressure</p>	 <p>Orbita Orbit</p>
 <p>Attacco aria Air connection</p>	 <p>Velocità nastro Belt speed</p>
 <p>Diametro interno tubo aria Air hose int. diameter</p>	 <p>Dimensione nastro Belt dimension</p>
 <p>Consumo aria medio Average air consumption</p>	 <p>Aghi Needles</p>
 <p>Peso - massa Wheight</p>	 <p>Capacità rivetti Rivet capacity</p>
 <p>Pressione sonora (PNEUROP8N-1) Sound pressure (PNEUROP8N-1)</p>	 <p>Corsa lama - colpi 1' - Frequenza Blade stroke - strokes 1' - Frequency</p>
 <p>Vibrazioni (ISO8662-1) Vibration level (ISO8662-1)</p>	 <p>Attacco Drive</p>
 <p>Potenza Power</p>	 <p>Potenza sonora Sound power</p>

Fiducia
Trust

Rispetto
Respect

Convenienza
Convenience

Reputazione
Reputation

FIDUCIA: una storia lunga 40 anni ci attribuisce l'esperienza e la competenza necessaria a realizzare prodotti affidabili e tecnologicamente avanzati che garantiscono lavori ben fatti grazie ad un'efficace continuità nell'utilizzo.

RISPETTO: da sempre la cortesia e l'attenzione che riserviamo ai nostri partner rivenditori punta a semplificare al massimo l'impegno, da parte di questi ultimi, nella proposta dei nostri prodotti al mercato dei professionisti utilizzatori.

CONVENIENZA: una gamma di prodotti completa, unita a un'ampia disponibilità di magazzino e a rapidissimi tempi di consegna, portano al partner rivenditore una sensibile riduzione dei costi con conseguente miglioramento della marginalità legata alla vendita dei nostri prodotti.

REPUTAZIONE: un'assistenza rapida e impeccabile e la professionale consulenza nella scelta degli utensili più adeguati alla destinazione d'uso, portano, al nostro partner rivenditore, un significativo incremento di immagine e di credibilità nei confronti del professionista utilizzatore.

TRUST: *we have forty years experience and knowledge to help us make and supply a range of technically advanced products which provide long life and reliability.*

RESPECT: *our policy is to work with our partner distributors and support them in their efforts to promote the sale of our products to the professional user market.*

CONVENIENCE: *we keep a complete range of products in stock and deliver quickly so our partner distributors only need to keep a small stock with a resultant improvement to their profit margins.*

REPUTATION: *our quick excellent service and provision of advice on the best tool for each application helps our partner distributors to improve their reputation with professional users.*

AIRTEC

AIRTEC s.r.l.u. Via Tarantelli, 2-4
42021 Barco di Bibbiano (RE) Italy

Tel +39 0522 24.65.18
E-mail: info@airtecsrl.it

www.airtecsrl.it